



NEPLAN AG

Oberwachtstrasse 2
8700 Küsnacht ZH
Switzerland

Phone: +41 44 914 36
66 Fax :+41 44 991 19
71

www.neplan.ch
bcp@neplan.ch

NEPLAN V555

POWER SYSTEM STABILIZER MODELS

Standard Dynamic Power System Stabilizers in NEPLAN Power System Analysis Tool

Contents

General	5
Per Unit (p.u.) System:	5
Power System PSS Diagram	5
Input Signals to the PSS System:	5
Output Signals to the PSS System:	6
Inputs <<enumeration>> of PSSs, STEREOType <<enum>>	6
PSS – SIMPLE	7
Parameters	Error! Bookmark not defined.
Equivalent model in CIM/CGMES:	7
- No CIM/CGMES model	7
PSS – Conventional PSS	8
Parameters	Error! Bookmark not defined.
Equivalent model in CIM/CGMES:	8
- No CIM/CGMES model	8
PSS - IEE2ST	9
Parameters	Error! Bookmark not defined.
Equivalent model in CIM/CGMES:	10
- Pss2ST	10
PSS - IEEEEST	11
Parameters	Error! Bookmark not defined.
Equivalent model in CIM/CGMES:	11
- No CIM/CGMES model	11
PSS - PSS1	12
Parameters	Error! Bookmark not defined.
Equivalent model in CIM/CGMES:	12
- No CIM/CGMES model	12
PSS – PSS1 CIM/CGMES	13
Parameters	Error! Bookmark not defined.
Equivalent model in CIM/CGMES:	13
- Pss1	13
PSS - PSS2	14
Parameters	Error! Bookmark not defined.

Equivalent model in CIM/CGMES:	14
- No CIM/CGMES model	14
PSS - PSS3	15
Parameters	Error! Bookmark not defined.
Equivalent model in CIM/CGMES:	15
- No CIM/CGMES model	15
PSS – PSS1A	16
Parameters	Error! Bookmark not defined.
Equivalent model in CIM/CGMES:	16
- PssIEEE1A	16
PSS – PSS1A CIM/CGMES	17
Parameters	Error! Bookmark not defined.
Equivalent model in CIM/CGMES:	17
- Pss1A	17
PSS - PSS2A	18
Parameters	Error! Bookmark not defined.
Equivalent model in CIM/CGMES:	19
- No CIM/CGMES model	19
PSS - PSS2B	20
Parameters	Error! Bookmark not defined.
Equivalent model in CIM/CGMES:	21
- Pss2B	21
PSS - PSS2B CIM/CGMES	22
Parameters	Error! Bookmark not defined.
Equivalent model in CIM/CGMES:	23
- PssIEEE2B	23
PSS – PSS3B	24
Parameters	Error! Bookmark not defined.
Equivalent model in CIM/CGMES:	24
- PssIEEE3B	24
PSS – PSS4B	25
Parameters	Error! Bookmark not defined.
Equivalent model in CIM/CGMES:	26
- PssIEEE4B	26
PSS – PSS5	27

Parameters	
Equivalent model in CIM/CGMES:	
- Pss5	27
	27
PSS – PSSELIN2	28
Parameters	
Equivalent model in CIM/CGMES:	
- PssELIN2	28
	28
PSS – PSSSH	29
Parameters	
Equivalent model in CIM/CGMES:	
- PssSH	29
	29
PSS – PSSSK	30
Parameters	
Equivalent model in CIM/CGMES:	
- PssSK	30
	30
PSS – PTIST1	31
Parameters	
Equivalent model in CIM/CGMES:	
- PssPTIST1	31
	31
PSS – PTIST3	32
Parameters	
Equivalent model in CIM/CGMES:	
- PssPTIST3	33
	33
PSS - STAB1	34
Parameters	
Equivalent model in CIM/CGMES:	
- No CIM/CGMES model	34
	34
PSS - STAB2A	35
Parameters	
Equivalent model in CIM/CGMES:	
- No CIM/CGMES model	35
	35
PSS - STAB3	36
Parameters	
Equivalent model in CIM/CGMES:	
- No CIM/CGMES model	36
	36
Error! Bookmark not defined.	
	27
	27
Error! Bookmark not defined.	
	28
	28
Error! Bookmark not defined.	
	29
	29
Error! Bookmark not defined.	
	30
	30
Error! Bookmark not defined.	
	31
	31
Error! Bookmark not defined.	
	33
	33
Error! Bookmark not defined.	
	34
	34
Error! Bookmark not defined.	
	35
	35
Error! Bookmark not defined.	
	36
	36

PSS - STAB4

Parameters

Equivalent model in CIM/CGMES:

- PssSB4

37

Error! Bookmark not defined.

37

37

PSS - STBSVC

Parameters

Equivalent model in CIM/CGMES:

- No CIM/CGMES model

38

Error! Bookmark not defined.

38

38

PSS - ST2CUT

Parameters

Equivalent model in CIM/CGMES:

- PssWECC

39

Error! Bookmark not defined.

40

40

Power Systems Stabilizer Models

General

The power system stabilizer (PSS) model provides an input (VPSS) to the excitation system model to improve damping of system oscillations. A variety of input signals may be used depending on the particular design.

ENTSO-E, an association of the European electricity transmission system operators, selected the Common Information Model (CIM) standards of the International Electrotechnical Commission (IEC) as a basis for its own CIM standards. These standards aim at ensuring the reliability of grid models and market information exchanges.

In 2013, ENTSO-E adopted a new standard for grid models exchange called the Common Grid Model Exchange Standard (CGMES). The CGMES is a superset of the IEC CIM/CGMES standards (belonging to IEC CIM16). It was developed to meet necessary requirements for the transmission system operators, which exchange data in the areas of system operations, network planning and integrated electricity markets.

All the CIM/CGMES regulators models are included in NEPLAN Power System Analysis Tools.

Per Unit (p.u.) System:

The p.u. values are based on the machine or Static Var Compensator (SVC) ratings.

Power System PSS Diagram

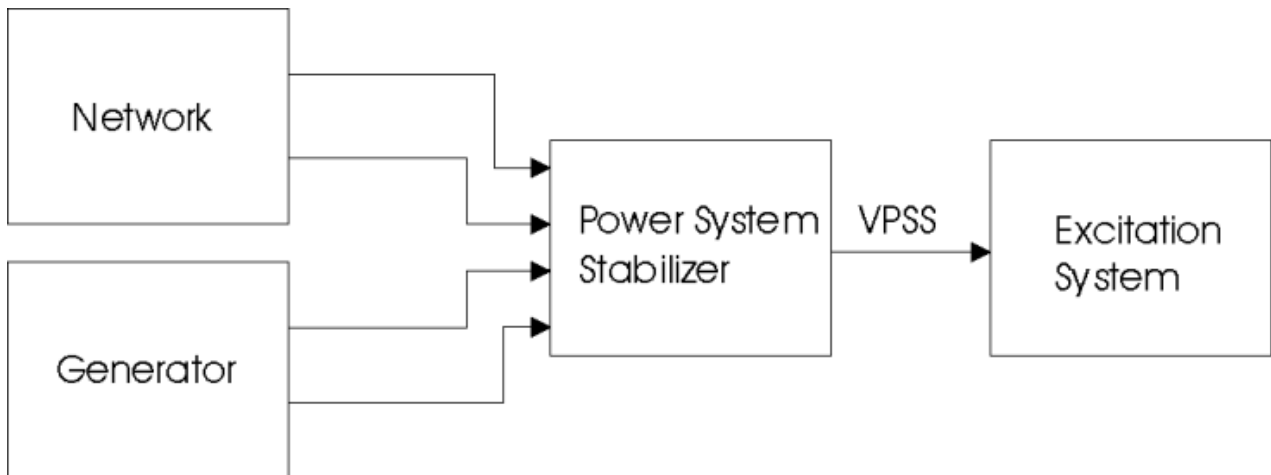

Input Signals to the PSS System:

V	Bus voltage, positive sequence, p.u.
I	Stator output current, positive sequence, p.u.
VT	Terminal voltage on the machine terminals compensated for the unit transformer reactance if it is specified.
F	Frequency in p.u. on the associated node
W	Rotor speed (synchronous machine).
TM	Mechanical torque (synchronous machine).
P	Active power in an AC-line or synchronous machine. Positive power is the

	INJECTED power at the FIRST bus of a line.
PMECH	Accelerating power, i.e. mechanical power minus active electrical power in p.u. of machine base.
QE	Reactive power in a line
IE	AC current magnitude in a line.

Output Signals to the PSS System:

VPSS	System PSS output signals (p.u.)
------	----------------------------------

Inputs <<enumeration>> of PSSs, STEREO TYPE <<enum>>

Input signal type (**SW**). In Dynamics modelling, commonly represented by j parameter <<enumeration>> InputSignalKind

0	Input signal is rotor or shaft speed (angular frequency)	<<enum>> rotorSpeed
1	Input signal is rotor or shaft angular frequency deviation	<<enum>> inputAddedToErrorSignal
2	Input signal is bus voltage frequency. This could be a terminal frequency or remote frequency	<<enum>> busFrequency
3	Input signal is deviation of bus voltage frequency. This could be a terminal frequency deviation or remote frequency deviation	<<enum>> inputHVgateVoltageOutput
4	Input signal is generator electrical power on rated S	<<enum>> generatorElectricalPower
5	Input signal is generating accelerating power	<<enum>> generatorAcceleratingPower
6	Input signal is bus voltage. This could be a terminal voltage or remote voltage	<<enum>> busVoltage
7	Input signal is derivative of bus voltage. This could be a terminal voltage derivative or remote voltage derivative	<<enum>> busVoltageDerivative
8	Input signal is amplitude of remote branch current	<<enum>> branchCurrent
9	Input signal is generator field current	<<enum>> fieldCurrent

PSS – SIMPLE

PSS simple model.

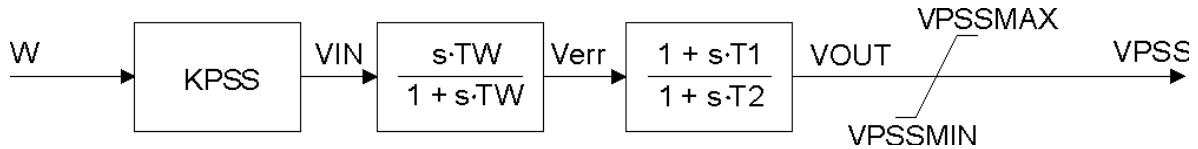

Parameters

NAME	Type	Description
KPSS	PU	Gain
TW	Seconds	Washout time constant
T1	Seconds	Time Constant
T2	Seconds	Time Constant
VPSSMAX	PU	Maximum PSS output
VPSSMIN	PU	Minimum PSS output

Notes

Equivalent model in CIM/CGMES:

- No CIM/CGMES model

PSS – Conventional PSS

PSS simple model.

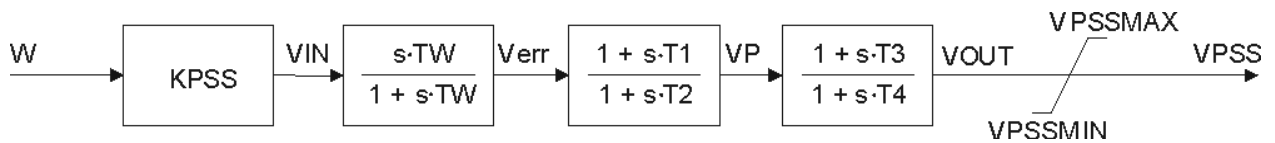

Parameters

NAME	Type	Description
KPSS	PU	Gain
TW	Seconds	Washout time constant
T1	Seconds	Time Constant
T2	Seconds	Time Constant
T3	Seconds	Time Constant
T4	Seconds	Time Constant
VPSSMAX	PU	Maximum PSS output
VPSSMIN	PU	Minimum PSS output

Notes

Equivalent model in CIM/CGMES:

- No CIM/CGMES model

PSS - IEE2ST

IEEE Stabilizing Model with Dual-Input Signals

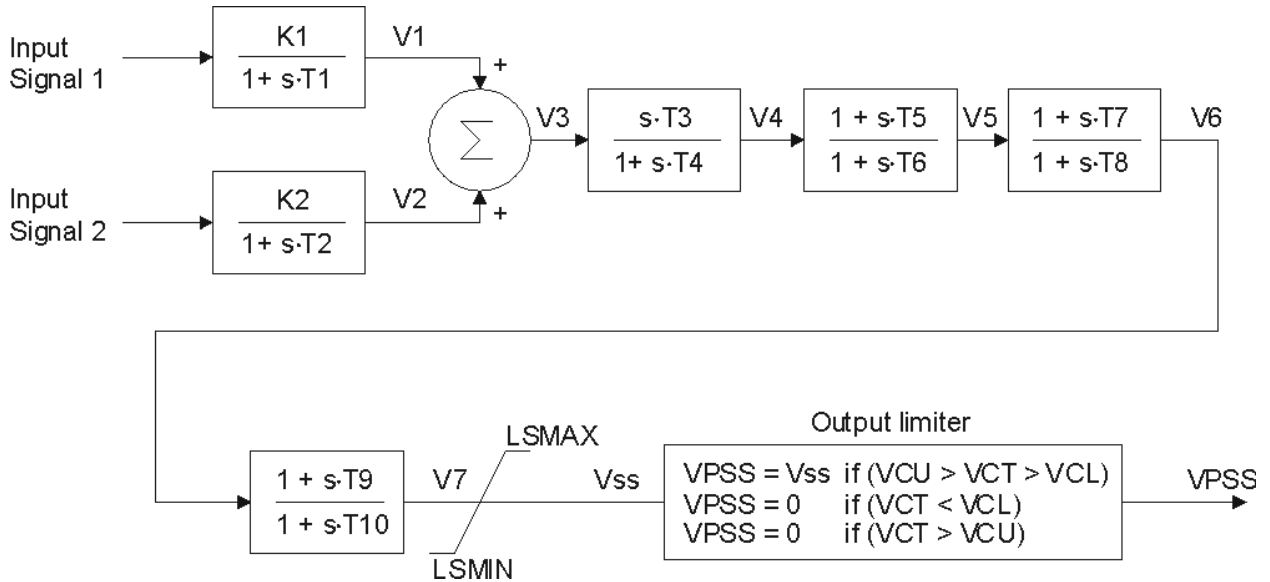

Parameters

NAME	Type	Description
SWS1*	enum	Type of input signal #1. Typical Value = rotorAngularFrequencyDeviation
SWS2*	enum	Type of input signal #2. Typical Value = generatorElectricalPower
K1	PU	Gain
K2	PU	Gain
T1	Second	Time constant
T2	Second	Time constant
T3	Second	Time constant
T4	Second	Time constant
T5	Second	Time constant
T6	Second	Time constant
T7	Second	Time constant
T8	Second	Time constant
T9	Second	Time constant
T10	Second	Time constant
LSMAX	PU	Limiter
LSMIN	PU	Limiter
VCL	PU	Cutoff limiter
VCU	PU	Cutoff limiter

* Description pag. 6

Parameters Range:

$0 \leq T_1 \leq 10$	$0 \leq T_8 \leq 10$
$0 \leq T_2 \leq 10$	$0 \leq T_9 \leq 10$
$0 < T_3 \leq 10$	$0 \leq T_{10} < 2$
$0.03 < T_4 \leq 10$	$0 < LSMAX < 0.3$
$0 \leq T_5 < 10$	$-0.3 < LSMIN < 0$
$0 \leq T_6 < 2$	$0 \leq VCU < 1.25$
$0 \leq T_7 \leq 10$	$-0.1 \leq VCL < 1.0$

Notes

Equivalent model in CIM/CGMES:
- Pss2ST

PSS - IEEEEST

IEEE Stabilizing Model

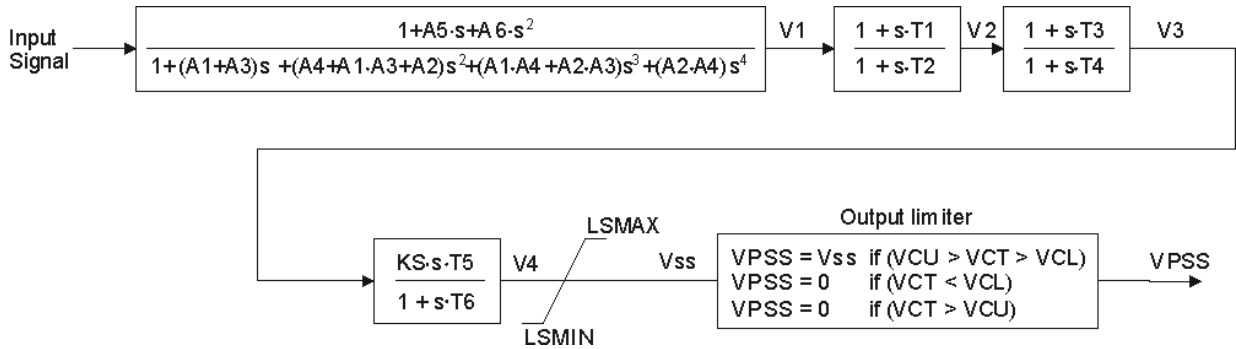

Parameters

NAME	Type	Description
SWS1*	enum	Type of input signal #1. Typical Value = rotorAngularFrequencyDeviation
A1	PU	Filter coefficient
A2	PU	Filter coefficient
A3	PU	Filter coefficient
A4	PU	Filter coefficient
A5	PU	Filter coefficient
A6	PU	Filter coefficient
T1	Seconds	Time constant
T2	Seconds	Time constant
T3	Seconds	Time constant
T4	Seconds	Time constant
T5	Seconds	Time constant
T6	Seconds	Time constant
KS	PU	Gain
LSMAX	PU	PSS output maximum limit
LSMIN	PU	PSS output minimum limit
VCL	PU	Cutoff limiter
VCU	PU	Cutoff limiter

* Description pag. 6

Parameters Range:

$$\begin{aligned}
 0 \leq T_1 \leq 10 & & 0.04 < T_6 < 2 \\
 0 \leq T_2 \leq 10 & & 0 < LSMAX < 0.3 \\
 0 \leq T_3 \leq 10 & & -0.3 < LSMIN < 0 \\
 0 \leq T_4 \leq 10 & & 0 \leq VCU < 1.25 \\
 0 < T_5 < 10 & & 0 \leq VCL < 1.0
 \end{aligned}$$

Notes

Equivalent model in CIM/CGMES:

- No CIM/CGMES model

PSS - PSS1

Power System PSS General Model.

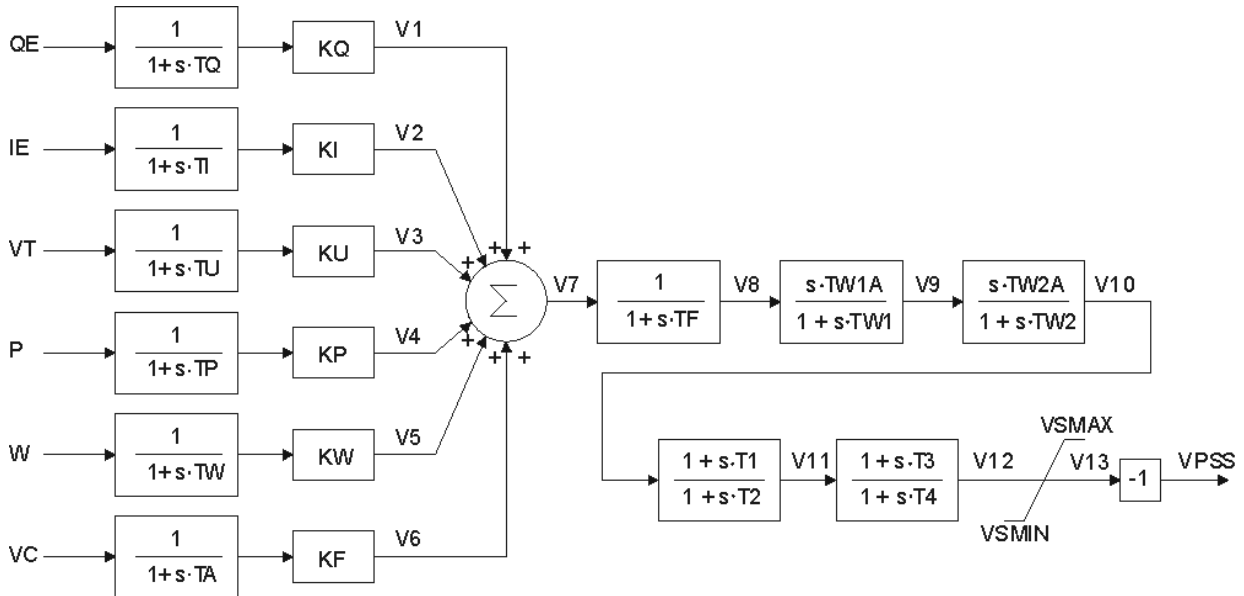

Parameters

NAME	Type	Description
KQ	PU	Reactive power gain
TQ	Seconds	Reactive power Time constant
KI	PU	Current Gain
TI	Seconds	Current Time constant
KU	PU	Terminal voltage gain
TU	Seconds	Terminal voltage Time constant
KP	PU	Active power gain
TP	Seconds	Active power Time constant
KW	PU	Rotor speed deviation gain
TW	Seconds	Rotor speed deviation Time constant
KF	PU	Voltage compensator gain
TA	Seconds	Voltage compensator Time constant
TF	Seconds	Time constant
TW1A	Seconds	Washout time constant
TW1	Seconds	Washout time constant
TW2A	Seconds	Washout time constant
TW2	Seconds	Washout time constant
T1	Seconds	Time constant
T2	Seconds	Time constant
T3	Seconds	Time constant
T4	Seconds	Time constant
VSMAX	PU	PSS output maximum limit
VSMIN	PU	PSS output minimum limit

Notes

Equivalent model in CIM/CGMES:
 - No CIM/CGMES model

PSS – PSS1 CIM/CGMES

Italian PSS - three input PSS (speed, frequency, power). Entsoe-CIM/CGMES model.

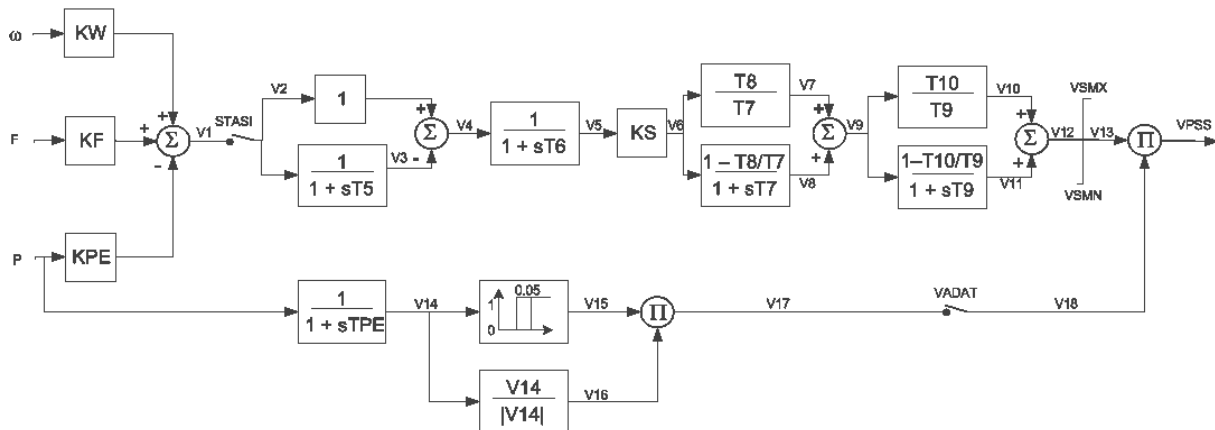

Parameters

NAME	Type	Description
KF	pu	Frequency power input gain
KPE	pu	Electric power input gain
KS	pu	PSS gain
KW	pu	Shaft speed power input gain
PMIN	pu	Minimum power PSS enabling
T10	Seconds	Lead/lag time constant
T5	Seconds	Washout
T6	Seconds	Filter time constant
T7	Seconds	Lead/lag time constant
T8	Seconds	Lead/lag time constant
T9	Seconds	Lead/lag time constant
TPE	Seconds	Electric power filter time constant
VADAT	Boolean	Signal selector, if VADAT=1 the switch is closed (Generator Power is greater than Pmin), else it is open (Pe is smaller than Pmin)
VSMN	pu	PSS output max limit
VSMX	pu	PSS output min limit

Notes

Equivalent model in CIM/CGMES:

- Pss1

PSS - PSS2

Power system PSS, ASEA type QAVD 101

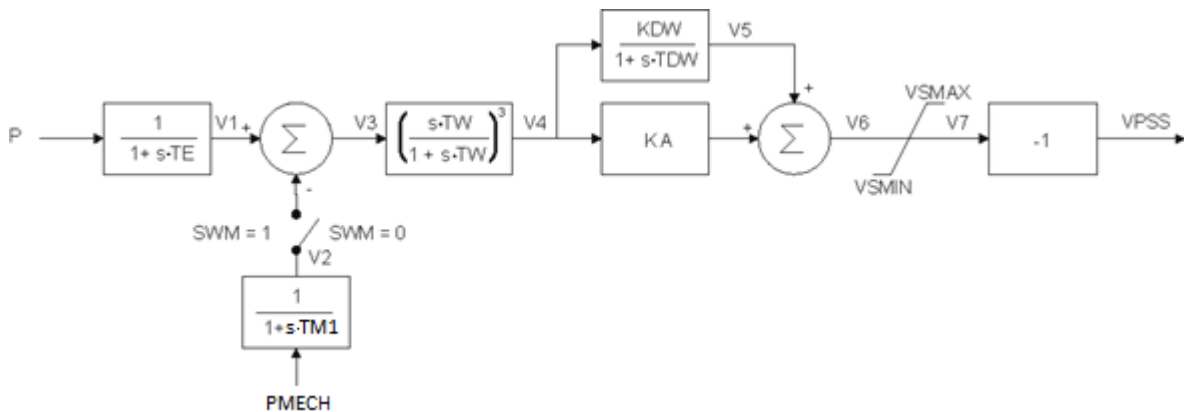

Parameters

NAME	Type	Description
SWM	Boolean	Switch control 0 = No compensating signal is applied 1 = Compensating signal is applied. TM has to be specified
TM1	Seconds	Load torque signal time constant
TE	Seconds	Active power time constant
TW	Seconds	Washout time constant
KDW	PU	Gain
TDW	Seconds	Time Constant
KA	PU	Gain
VSMAX	PU	PSS output maximum limit
VSMIN	PU	PSS output minimum limit

Notes

Equivalent model in CIM/CGMES:

- No CIM/CGMES model

PSS - PSS3

Power System PSS IEEE-model

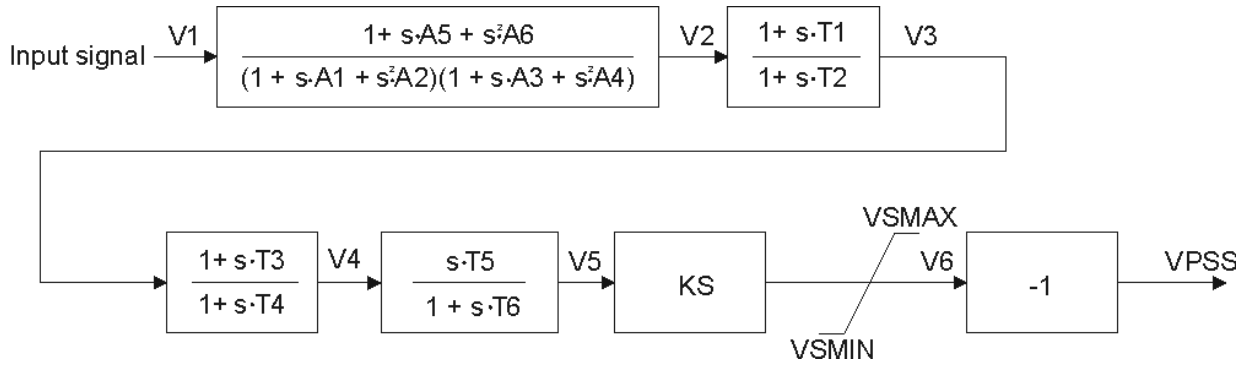

Parameters

NAME	Type	Description
SWI	enum	Input switch control: 0 = W-1, Synchronous machine rotor speed deviation is used as input 1 = P, Synchronous machine active power is used as input 2 = VT, Terminal voltage in p.u. is used as input 3 = TM, Mechanical torque in p.u. is used as input 4 = PMECH, Acceleration power in p.u. is used as input 5 = QE, Reactive power in the specified line is used as input 6 = IE, Current in the specified line is used as input
A1	PU	Filter coefficient
A2	PU	Filter coefficient
A3	PU	Filter coefficient
A4	PU	Filter coefficient
A5	PU	Filter coefficient
A6	PU	Filter coefficient
T1	Seconds	Time Constant
T2	Seconds	Time Constant
T3	Seconds	Time Constant
T4	Seconds	Time Constant
T5	Seconds	Time Constant
T6	Seconds	Time Constant
KS	PU	Gain
VSMAX	PU	PSS output maximum limit
VSMIN	PU	PSS output minimum limit
VCU	PU	Limiter
VCL	PU	Limiter

Notes

Output, switch limiter:

If $VT < VCL$ =====> $VPSS=0$
 If $VT > VCU$ =====> $VPSS=0$

Equivalent model in CIM/CGMES:

- No CIM/CGMES model

PSS – PSS1A

IEEE Std 421.5-2005 type PSS1A power system PSS model.

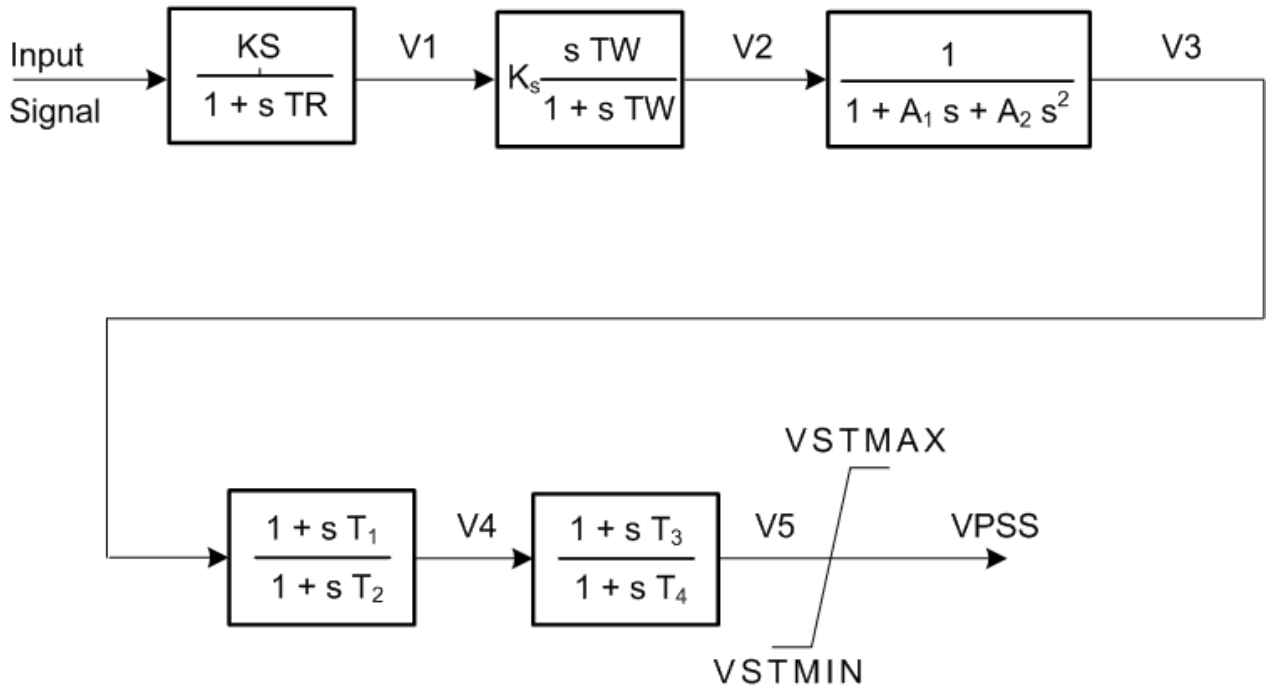

Parameters

NAME	Type	Description
SWS1*	enum	I Type of input signal. Typical Value = rotorAngularFrequencyDeviation
KS	PU	PSS gain
TR	Seconds	Transducer time constant
TW	Seconds	Washout time constant
A1	PU	PSS signal conditioning frequency filter constant
A2	PU	PSS signal conditioning frequency filter constant
T1	Seconds	Lead/lag time constant
T2	Seconds	Lead/lag time constant
T3	Seconds	Lead/lag time constant
T4	Seconds	Lead/lag time constant
VSTMAX	PU	Maximum PSS output
VSTMIN		Minimum PSS output

* Description pag. 6

Notes

Equivalent model in CIM/CGMES:

- PssIEEE1A

PSS – PSS1A CIM/CGMES

Single input power system PSS. It is a modified version in order to allow representation of various vendors' implementations on PSS type 1A.

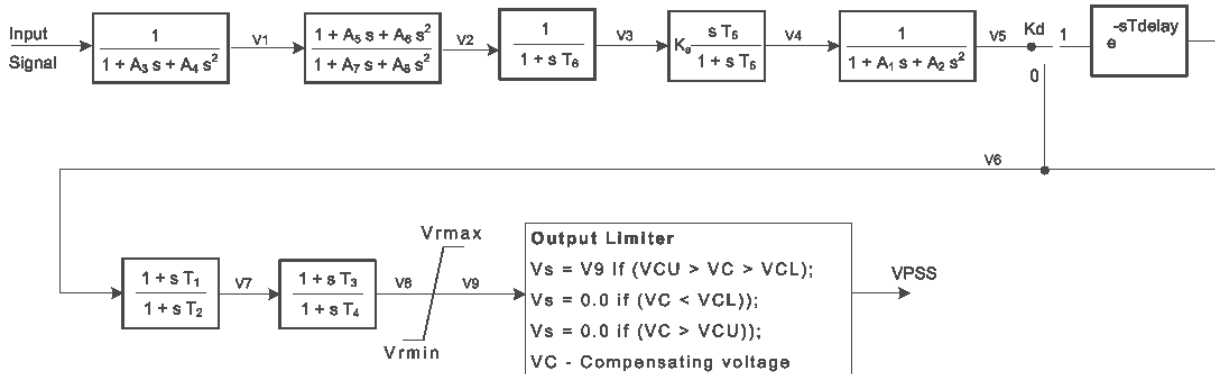

Parameters

NAME	Type	Description
A1	pu	Notch filter parameter
A2	pu	Notch filter parameter
A3	pu	Notch filter parameter
A4	pu	Notch filter parameter
A5	pu	Notch filter parameter
A6	pu	Notch filter parameter
A7	pu	Notch filter parameter
A8	pu	Notch filter parameter
KD	Boolean	Selector, if KD=1 the $e^{-sTDELAY}$ is used, else it not is used
KS	pu	PSS gain
T1	Seconds	Lead/lag time constant
T2	Seconds	Lead/lag time constant
T3	Seconds	Lead/lag time constant
T4	Seconds	Lead/lag time constant
T5	Seconds	Washout time constant
T6	Seconds	Transducer time constant
TDELAY	Seconds	Time constant
VCL	pu	PSS input cutoff threshold
VCU	pu	PSS input cutoff threshold
VRMAX	pu	Maximum PSS output
VRMIN	pu	Minimum PSS output
SWS1	enum	Input switch control * Input signal type. In Dynamics modelling, commonly represented by j parameter

* Description pag. 6

Notes

Equivalent model in CIM/CGMES:

- Pss1A

PSS - PSS2A

IEEE Dual-Input PSS Model

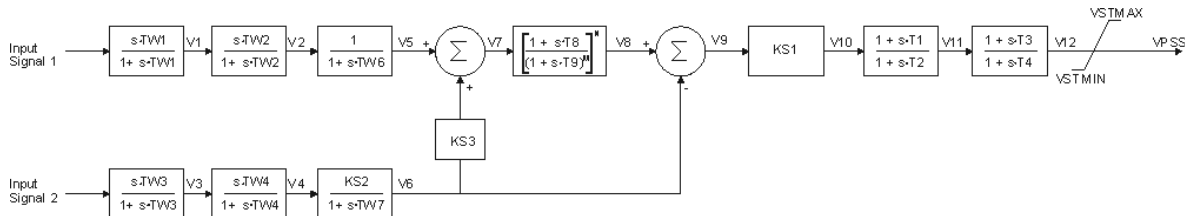

Parameters

NAME	Type	Description
SWS1	enum	Input 1, switch control 1 = W-1, Rotor speed deviation (pu) is used as input 2 = Frequency deviation at bus (pu) is used as input (Currently in NEPLAN as W-1, no remote frequency is implemented, but reserved for futur version) 3 = P, Electrical active power (pu) is used as input 4 = PМЕCH, Acceleration power (pu). is used as input 5 = VT, Bus Voltage (pu) is used as input 6 = dVT, Derivative of pu bus voltage. is used as input
SWS2	enum	Input 2, switch control 1 = W-1, Rotor speed deviation (pu) is used as input 2 = Frequency deviation at bus (pu) is used as input (Currently in NEPLAN as W-1, no remote frequency is implemented, but reserved for futur version) 3 = P, Electrical active power (pu) is used as input 4 = PМЕCH, Acceleration power (pu). is used as input 5 = VT, Bus Voltage (pu) is used as input 6 = dVT, Derivative of pu bus voltage. is used as input
TW1	Seconds	First washout on signal 1
TW2	Seconds	Second washout on signal 1
TW3	Seconds	First washout on signal 2
TW4	Seconds	Second washout on signal 2
TW6	Seconds	Time constant on signal 1
TW7	Seconds	Time constant on signal 2
T1	Seconds	Lead/lag time constant
T2	Seconds	Lead/lag time constant
T3	Seconds	Lead/lag time constant
T4	Seconds	Lead/lag time constant
T8	Seconds	Lead of ramp tracking filter
T9	Seconds	Lag of ramp tracking filter
T10	Seconds	Lead/lag time constant
T11	Seconds	Lead/lag time constant
KS1	PU	PSS gain
KS2	PU	Gain on signal 2
KS3	PU	Gain on signal 2 input before ramp-tracking filter
VSTMAX	PU	PSS output max limit
VSTMIN	PU	PSS output min limit
VSI1MAX	PU	Input signal #1 max limit
VSI1MIN	PU	Input signal #1 min limit
VSI2MAX	PU	Input signal #2 max limit
VSI2MIN	PU	Input signal #2 min limit
M	Integer	Denominator order of ramp tracking filter
N	Integer	Order of ramp tracking filter

Parameters Range:

$1.5 \leq TW1 \leq 15$	$0.02 < T9 < 2.0$
$1.5 \leq TW2 \leq 15$	$0.02 \leq T1 \leq 2.0$
$1.5 \leq TW3 \leq 15$	$0.02 \leq T3 \leq 2.0$

$$1.5 \leq TW4 \leq 15 \qquad 0.02 \leq T2 \leq 6.0$$

$$0.02 < T6 \qquad 0.02 \leq T4 \leq 6.0$$

$$0.02 < T7 \qquad 0 < VSTMAX < 0.99$$

$$0.02 < T8 \neq 2 \qquad -0.3 \leq VSTMIN \leq 0$$

Notes

Switch SWS1 (input signal 1):

If SWS1 = 1	W-1, Rotor speed deviation (pu) is used as input 1
If SWS1 = 2	Frequency deviation at bus (pu) is used as input 1
If SWS1 = 3	P, Electrical active power (pu) is used as input 1
If SWS1 = 4	PMECH, Acceleration power (pu). is used as input 1
If SWS1 = 5	VT, Bus Voltage (pu) is used as input 1
If SWS1 = 6	dVT, Derivative of pu bus voltage. is used as input 1

Switch SWS2 (input signal 2):

If SWS2 = 1	W-1, Rotor speed deviation (pu) is used as input 2
If SWS2 = 2	Frequency deviation at bus (pu) is used as input 2
If SWS2 = 3	P, Electrical active power (pu) is used as input 2
If SWS2 = 4	PMECH, Acceleration power (pu). is used as input 2
If SWS2 = 5	VT, Bus Voltage (pu) is used as input 2
If SWS2 = 6	dVT, Derivative of pu bus voltage. is used as input 2

Model Notes:

Ramp Tracking Filter

$$M \geq 0$$

$$N \geq 0$$

$$M * N \leq 8$$

If M = 0, then N is set equal to 0

To bypass: set M = N = 0

Washouts

To bypass second washout, first signal: set TW2 = 0

To bypass second washout, second signal: set TW4 = 0

Transducers

To bypass first signal transducer: set T6 = 0

To bypass second signal transducer: set T7 = 0

Lead-Lags

To bypass first lead-lag: set T1 = T2 = 0

To bypass second lead-lag: set T3 = T4 = 0

Equivalent model in CIM/CGMES:

- No CIM/CGMES model

PSS - PSS2B

Modified IEEE Dual-Input PSS Model

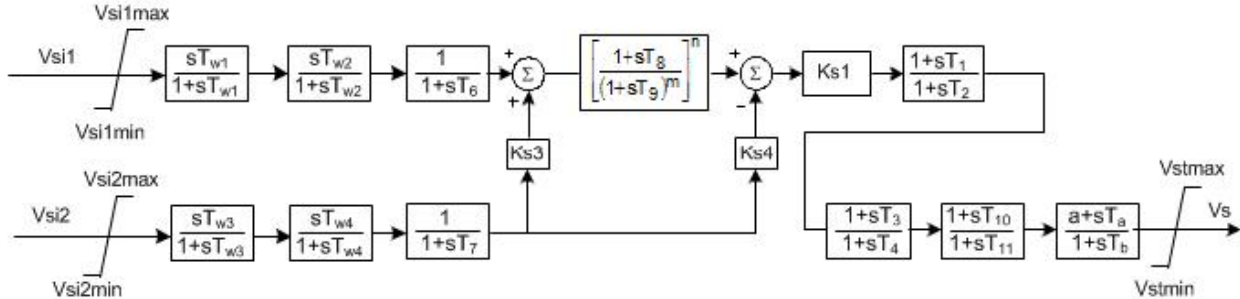

Parameters

NAME	Type	Description
SWS1	enum	* Type of input signal #1. Typical Value = rotorSpeed
SWS2	enum	* Type of input signal #2. Typical Value = generatorElectricalPower
TW1	Seconds	First washout on signal 1
TW2	Seconds	Second washout on signal 1
TW3	Seconds	First washout on signal 2
TW4	Seconds	Second washout on signal 2
TW6	Seconds	Time constant on signal 1
TW7	Seconds	Time constant on signal 2
T1	Seconds	Lead/lag time constant
T2	Seconds	Lead/lag time constant
T3	Seconds	Lead/lag time constant
T4	Seconds	Lead/lag time constant
T8	Seconds	Lead of ramp tracking filter
T9	Seconds	Lag of ramp tracking filter
T10	Seconds	Lead/lag time constant
T11	Seconds	Lead/lag time constant
KS1	PU	PSS gain
KS2	PU	Gain on signal 2
KS3	PU	Gain on signal 2 input before ramp-tracking filter
KS4	PU	Gain on signal 2 input after ramp-tracking filter
VSTMAX	PU	PSS output max limit
VSTMIN	PU	PSS output min limit
VSI1MAX	PU	Input signal #1 max limit
VSI1MIN	PU	Input signal #1 min limit
VSI2MAX	PU	Input signal #2 max limit
VSI2MIN	PU	Input signal #2 min limit
AA	PU	Numerator constant
TA	Seconds	Lead/lag time constant
TB	Seconds	Lead/lag time constant
M	Integer	Denominator order of ramp tracking filter
N	Integer	Order of ramp tracking filter

* Description pag. 6

Parameters Range:

$1.5 \leq TW1 \leq 15$	$0.02 < T9 < 2.0$
$1.5 \leq TW2 \leq 15$	$0.02 \leq T1 \leq 2.0$
$1.5 \leq TW3 \leq 15$	$0.02 \leq T3 \leq 2.0$
$1.5 \leq TW4 \leq 15$	$0.02 \leq T2 \leq 6.0$
$0.02 < T6$	$0.02 \leq T4 \leq 6.0$
$0.02 < T7$	$0 < VSTMAX < 0.99$

$0.02 < T8$

$-0.3 \leq VSTMIN \leq 0$

Notes

Ramp Tracking Filter

$M \geq 0$

$N \geq 0$

$M * N \leq 8$

If $M = 0$, then N is set equal to 0

To bypass: set $M = N = 0$

Equivalent model in CIM/CGMES:

- Pss2B

PSS - PSS2B CIM/CGMES

Modified IEEE Dual-Input PSS Model

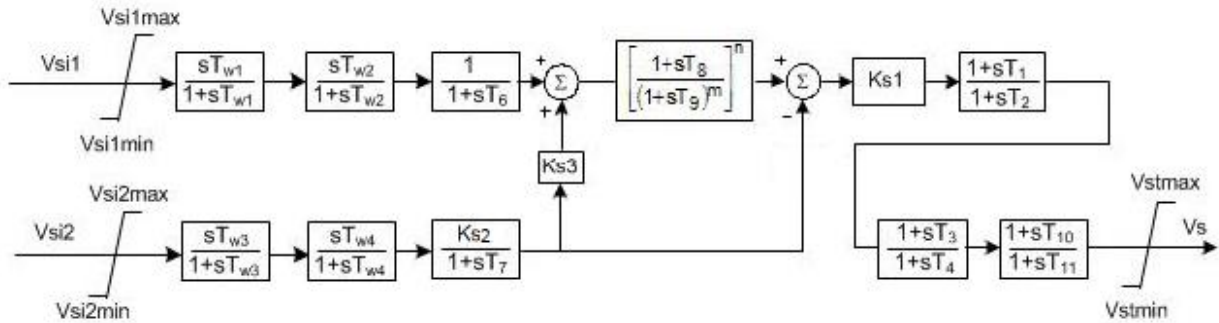

Parameters

NAME	Type	Description
SWS1	enum	* Type of input signal #1. Typical Value = rotorSpeed
SWS2	enum	* Type of input signal #2. Typical Value = generatorElectricalPower
TW1	Seconds	First washout on signal 1
TW2	Seconds	Second washout on signal 1
TW3	Seconds	First washout on signal 2
TW4	Seconds	Second washout on signal 2
TW6	Seconds	Time constant on signal 1
TW7	Seconds	Time constant on signal 2
T1	Seconds	Lead/lag time constant
T2	Seconds	Lead/lag time constant
T3	Seconds	Lead/lag time constant
T4	Seconds	Lead/lag time constant
T8	Seconds	Lead of ramp tracking filter
T9	Seconds	Lag of ramp tracking filter
T10	Seconds	Lead/lag time constant
T11	Seconds	Lead/lag time constant
KS1	PU	PSS gain
KS2	PU	Gain on signal 2
KS3	PU	Gain on signal 2 input before ramp-tracking filter
KS4	PU	Gain on signal 2 input after ramp-tracking filter
VSTMAX	PU	PSS output max limit
VSTMIN	PU	PSS output min limit
VSI1MAX	PU	Input signal #1 max limit
VSI1MIN	PU	Input signal #1 min limit
VSI2MAX	PU	Input signal #2 max limit
VSI2MIN	PU	Input signal #2 min limit
M	Integer	Denominator order of ramp tracking filter
N	Integer	Order of ramp tracking filter

* Description pag. 6

Notes

Ramp Tracking Filter

$M \geq 0$

$N \geq 0$

$M * N \leq 8$

If $M = 0$, then N is set equal to 0

To bypass: set $M = N = 0$

Equivalent model in CIM/CGMES:
- PssIEEE2B

PSS – PSS3B

IEEE Std 421.5-2005 type PSS3B power system PSS model.

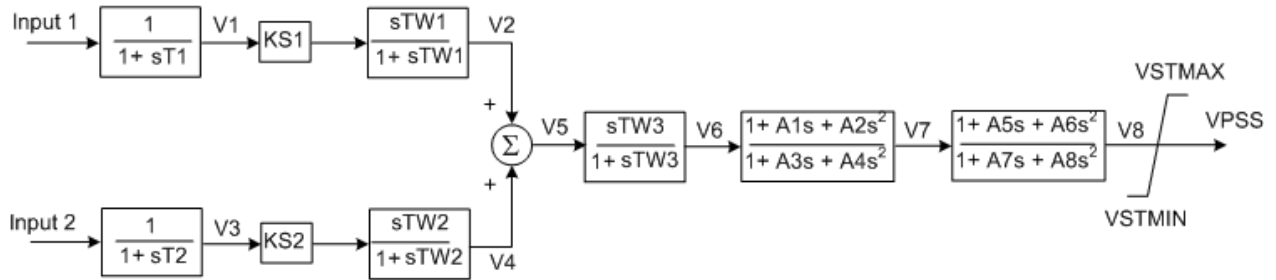

Parameters

NAME	Type	Description
SWS1*	enum	Type of input signal #1. Typical Value = generatorElectricalPower
SWS2*	enum	Type of input signal #2. Typical Value = rotorSpeed
TW1	Seconds	Washout time constant
TW2	Seconds	Washout time constant
TW3	Seconds	Washout time constant
KS1	PU	Gain on signal 1
KS2	PU	Gain on signal 2
T1	Seconds	Transducer time constant
T2	Seconds	Transducer time constant
VSTMAX	PU	PSS output max limit
VSTMIN	PU	PSS output MIN limit
A1	PU	Notch filter parameter
A2	PU	Notch filter parameter
A3	PU	Notch filter parameter
A4	PU	Notch filter parameter
A5	PU	Notch filter parameter
A6	PU	Notch filter parameter
A7	PU	Notch filter parameter
A8	PU	Notch filter parameter

* Description pag. 6

Notes

Equivalent model in CIM/CGMES:

- PssIEEE3B

PSS – PSS4B

IEEE Std 421.5-2005 type PSS2B power system PSS model.

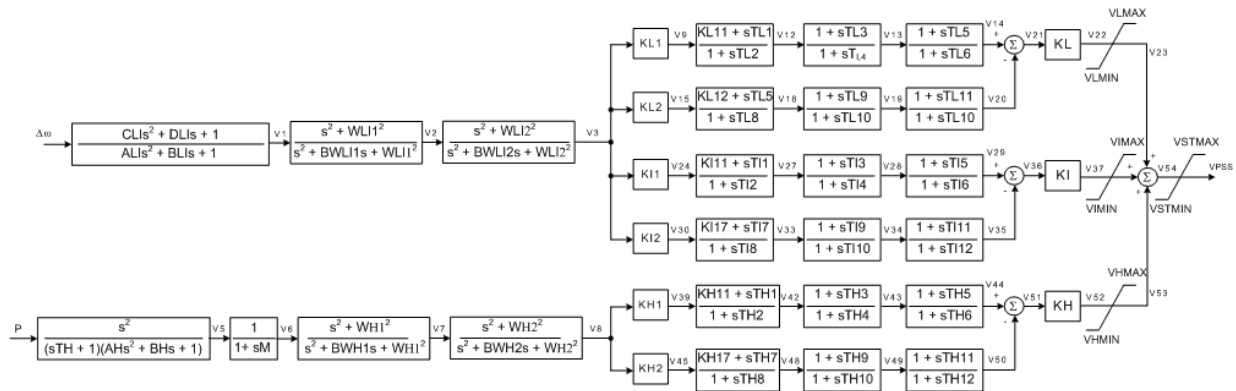

Parameters

NAME	Type	Description
CLI	PU	Transducer factor
DLI	PU	Transducer factor
ALI	PU	Transducer factor
BLI	PU	Transducer factor
wLI1	PU	First notch filter factor
BwLI1	PU	First notch filter factor
wLI2	PU	Second notch filter factor
BwLI2	PU	Second notch filter factor
TH	Seconds	Transducer Time constant
AH	PU	Transducer factor
BH	PU	Transducer factor
M	PU	Transducer factor
BwH1	PU	First notch filter factor
wH1	PU	First notch filter factor
BwH2	PU	Second notch filter factor
wH2	PU	Second notch filter factor
KL1	PU	Low band differential filter gain
KL2	PU	Low band differential filter gain
KL11	PU	Low band first lead-lag blocks coefficient
KL17	PU	Low band first lead-lag blocks coefficient
KL	PU	Low band gain
TL1	Seconds	Low band time constant
TL2	Seconds	Low band time constant
TL3	Seconds	Low band time constant
TL4	Seconds	Low band time constant
TL5	Seconds	Low band time constant
TL6	Seconds	Low band time constant
TL7	Seconds	Low band time constant
TL8	Seconds	Low band time constant
TL9	Seconds	Low band time constant
TL10	Seconds	Low band time constant
TL11	Seconds	Low band time constant
TI12	Seconds	Low band time constant
VLMAX	PU	Low band output maximum limit

VLMIN	PU	Low band output minimum limit
KI1	PU	Intermediate band differential filter gain
KI2	PU	Intermediate band differential filter gain
KI11	PU	Intermediate band first lead-lag blocks coefficient
KI17	PU	Intermediate band first lead-lag blocks coefficient
KI	PU	Intermediate band gain
T11	Seconds	Intermediate band time constant
T12	Seconds	Intermediate band time constant
T13	Seconds	Intermediate band time constant
T14	Seconds	Intermediate band time constant
T15	Seconds	Intermediate band time constant
T16	Seconds	Intermediate band time constant
T17	Seconds	Intermediate band time constant
T18	Seconds	Intermediate band time constant
T19	Seconds	Intermediate band time constant
T110	Seconds	Intermediate band time constant
T111	Seconds	Intermediate band time constant
T112	Seconds	Intermediate band time constant
VIMAX	PU	Intermediate band output maximum limit
VIMIN	PU	Intermediate band output minimum limit
KH1	PU	High band differential filter gain
KH2	PU	High band differential filter gain
KH11	PU	High band first lead-lag blocks coefficient
KH17	PU	High band first lead-lag blocks coefficient
TH1	Seconds	High band time constant
TH2	Seconds	High band time constant
TH3	Seconds	High band time constant
TH4	Seconds	High band time constant
TH5	Seconds	High band time constant
TH6	Seconds	High band time constant
TH7	Seconds	High band time constant
TH8	Seconds	High band time constant
TH9	Seconds	High band time constant
TH10	Seconds	High band time constant
TH11	Seconds	High band time constant
TH12	Seconds	High band time constant
KH	PU	High band gain
VHMAX	PU	High band output maximum limit
VHMIN	PU	High band output minimum limit
VSTMAX	PU	PSS output maximum limit
VSTMIN	PU	PSS output minimum limit

Notes

Equivalent model in CIM/CGMES:

- PssIEEE4B

PSS – PSS5

Italian PSS

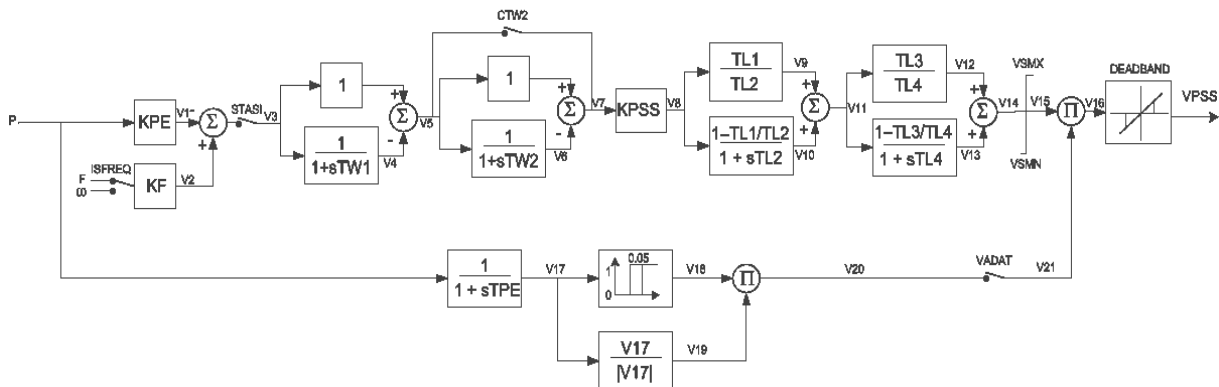

Parameters

NAME	Type	Description
CTW2	Boolean	Selector for Second washout enabling, CTW2=1 (selector ON) second washout filter is bypassed, else (selector OFF) second washout filter in use
DEADBAND	pu	PSS output dead band
ISFREQ	Boolean	Selector for Frequency/shaft speed input, ISFREQ=1 switch on speed, else switch on frequency
KF	pu	Frequency/shaft speed input gain
KPE	pu	Electric power input gain
KPSS	pu	PSS gain
PMM	pu	Minimum power PSS enabling
TL1	Seconds	Lead/lag time constant
TL2	Seconds	Lead/lag time constant
TL3	Seconds	Lead/lag time constant
TL4	Seconds	Lead/lag time constant
TPE	Seconds	Electric power filter time constant
TW1	Seconds	First WashOut
TW2	Seconds	Second WashOut
VADAT	Boolean	Signal selector, if VADAT=1 the switch is closed (Generator Power is greater than Pmin), else it is open (Pe is smaller than Pmin).
VSMN	pu	PSS output min limit
VSMX	pu	PSS output max limit

Notes

Equivalent model in CIM/CGMES:

- Pss5

PSS – PSSELIN2

Power system PSS typically associated with ExcELIN2 (though PssIEEE2B or Pss2B can also be used)

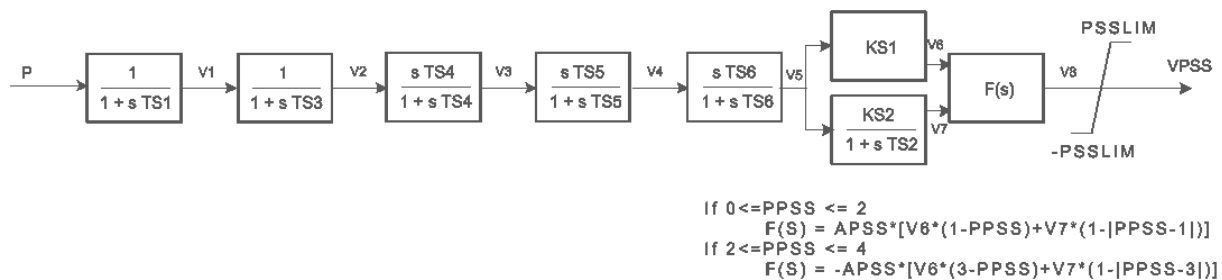

Parameters

NAME	Type	Description
APSS	pu	Coefficient
KS1	pu	Gain
KS2	pu	Gain
PPSS	pu	Coefficient, (≥ 0 and ≤ 4), check on the picture
PSSLIM	pu	PSS limiter
TS1	Seconds	Time constant
TS2	Seconds	Time constant
TS3	Seconds	Time constant
TS4	Seconds	Time constant
TS5	Seconds	Time constant
TS6	Seconds	Time constant

Notes

Equivalent model in CIM/CGMES:

- PssELIN2

PSS – PSSSH

Model for Siemens “H infinity” power system PSS with generator electrical power input.

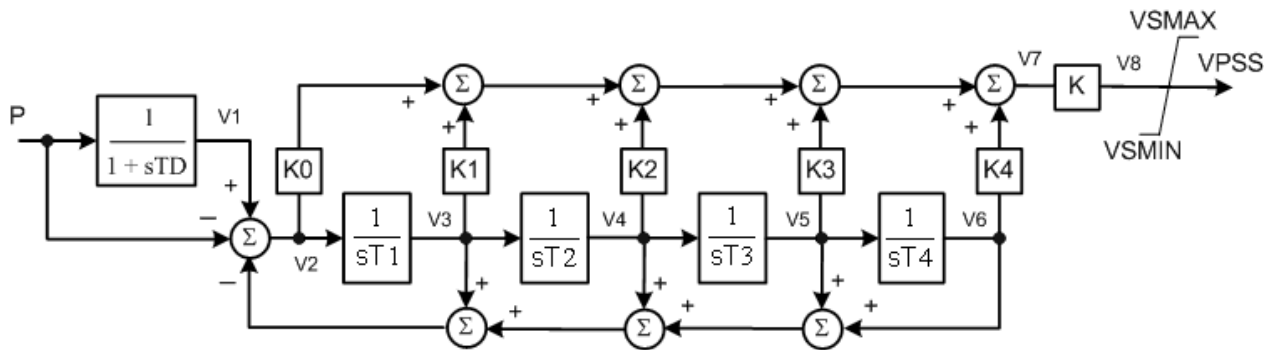

Parameters

NAME	Type	Description
K	PU	Main gain
K0	PU	Gain 0
K1	PU	Gain 1
K2	PU	Gain 2
K3	PU	Gain 3
K4	PU	Gain 4
TD	Seconds	Input time constant
T1	Seconds	Time constant 1
T2	Seconds	Time constant 2
T3	Seconds	Time constant 3
T4	Seconds	Time constant 4
VSMAX	PU	Output maximum limit
VSMIN	PU	Output minimum limit

Notes

Equivalent model in CIM/CGMES:

- PssSH

PSS – PSSSK

PSS Slovakian type – three inputs.

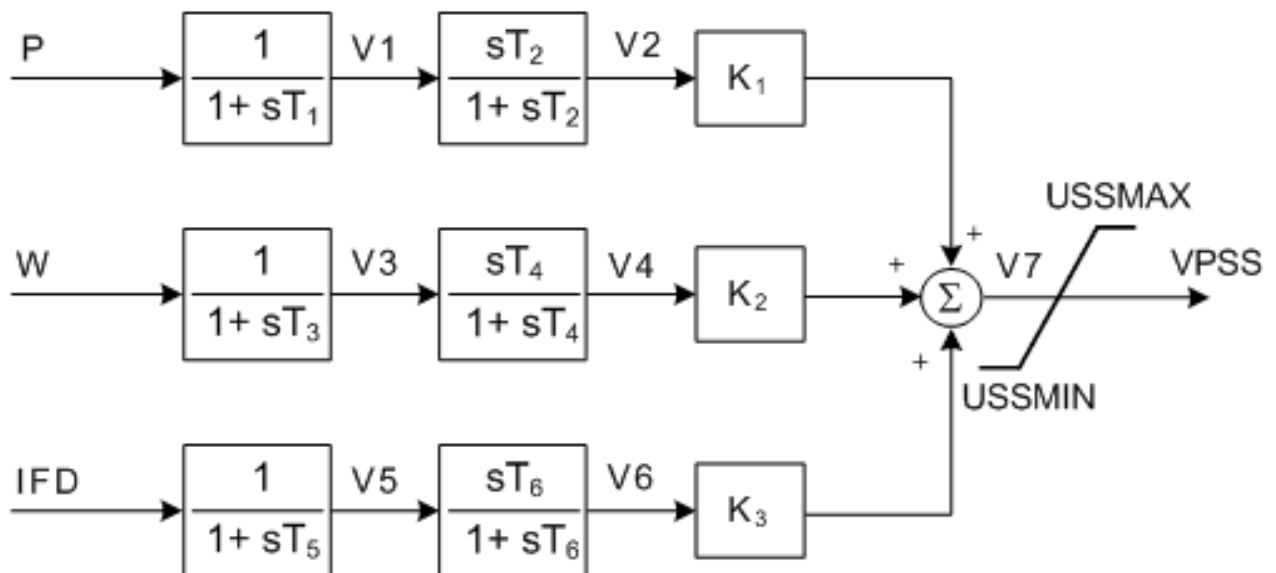

Parameters

NAME	Type	Description
K1	PU	Power gain
K2	PU	Rotor speed deviation gain
K3	PU	Field current gain
T1	Seconds	Power Time Constant
T2	Seconds	Power Time Constant
T3	Seconds	Rotor speed deviation Time Constant
T4	Seconds	Rotor speed deviation Time Constant
T5	Seconds	Field current Time Constant
T6	Seconds	Field current Time Constant
USSMAX	PU	Limiter
USSMIN	PU	Limiter

Notes

Equivalent model in CIM/CGMES:

- PssSK

PSS – PTIST1

PTI Microprocessor-Based PSS type 1.

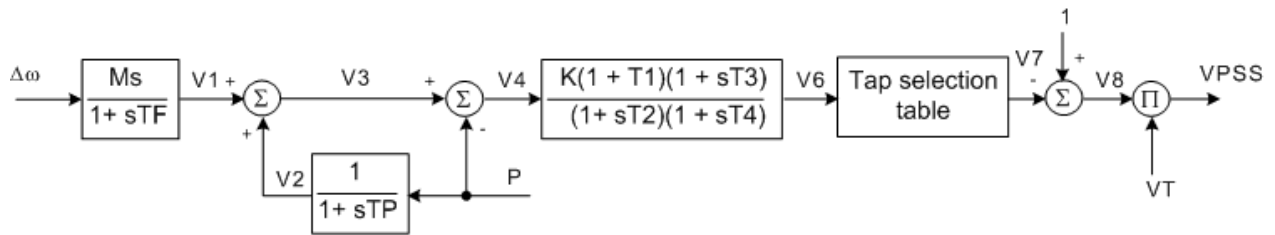

Parameters

NAME	Type	Description
DTF	Seconds	Time step frequency calculation
DTP	Seconds	Time step related to activation of controls
DTC	Seconds	Time step active power calculation
M	PU	$M=2 \cdot H$
TP	Seconds	Time constant
TF	Seconds	Time constant
K	PU	Gain
T1	Seconds	Time constant
T2	Seconds	Time constant
T3	Seconds	Time constant
T4	Seconds	Time constant

Notes

Equivalent model in CIM/CGMES:

- PssPTIST1

PSS – PTIST3

PTI Microprocessor-Based PSS type 3.

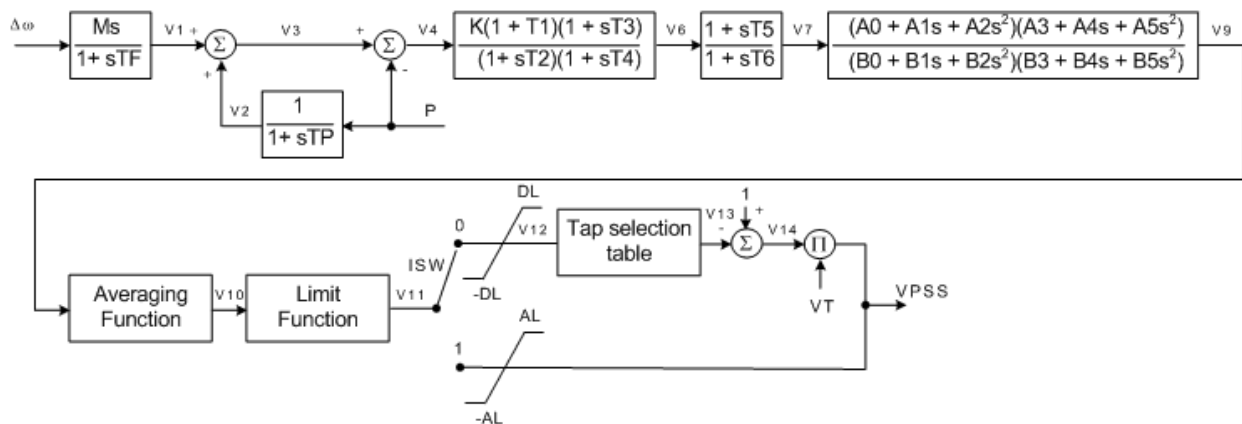

Parameters

NAME	Type	Description
DTF	Seconds	Time step frequency calculation
DTP	Seconds	Time step related to activation of controls
DTC	Seconds	Time step active power calculation
M	PU	$M=2 \cdot H$
TP	Seconds	Time constant
TF	Seconds	Time constant
K	PU	Gain
T1	Seconds	Time constant
T2	Seconds	Time constant
T3	Seconds	Time constant
T4	Seconds	Time constant
T5	Seconds	Time constant
T6	Seconds	Time constant
A0	PU	Filter coefficient
A1	PU	Limiter
A2	PU	Filter coefficient
B0	PU	Filter coefficient
B1	PU	Filter coefficient
B2	PU	Filter coefficient
A3	PU	Filter coefficient
A4	PU	Filter coefficient
A5	PU	Filter coefficient
B3	PU	Filter coefficient
B4	PU	Filter coefficient
B5	PU	Filter coefficient
ATHRES	PU	Threshold value above which output averaging will be bypassed (not used in NEPLAN)
DL	PU	Limiter
AL	PU	Limiter
LTHRES	PU	Threshold value (not used in NEPLAN)
PMIN	PU	Limiter (not used in NEPLAN)
ISW	Boolean	Digital/analog output switch (see block diagram) $0 = VPSS = VT \cdot V14$ $1 = VPSS = \text{limit}(V11, -AL, AL)$
NAV	PU	Number of control outputs to average (not used in NEPLAN)
NCL	PU	Number of counts at limit to active limit function (not used in NEPLAN)
NCR	PU	Number of counts until reset after limit function is triggered (not used in NEPLAN)

Notes

Some Parameters are not used currently in NEPLAN (ATHRES, LTHRES, PMIN, NAV, NCL, NCR). These parameters describe the “Averaging Function”, “Limit Function” and “Tap Selection Table”. The PTI manual is not clear about the exact use of these three functions.

Equivalent model in CIM/CGMES:

- PssPTIST3

PSS - STAB1

SPEED Sensitive Stabilizing Model

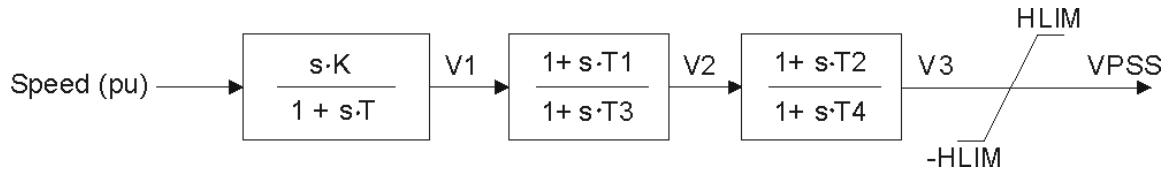

Parameters

NAME	Type	Description
K	PU	Gain
T	Seconds	Time constant
T1	Seconds	Time constant
T2	Seconds	Time constant
T3	Seconds	Time constant
T4	Seconds	Time constant
HLIM	PU	PSS output limit

Notes

Equivalent model in CIM/CGMES:

- No CIM/CGMES model

PSS - STAB2A

Power Sensitive Stabilizing Unit (ASEA).

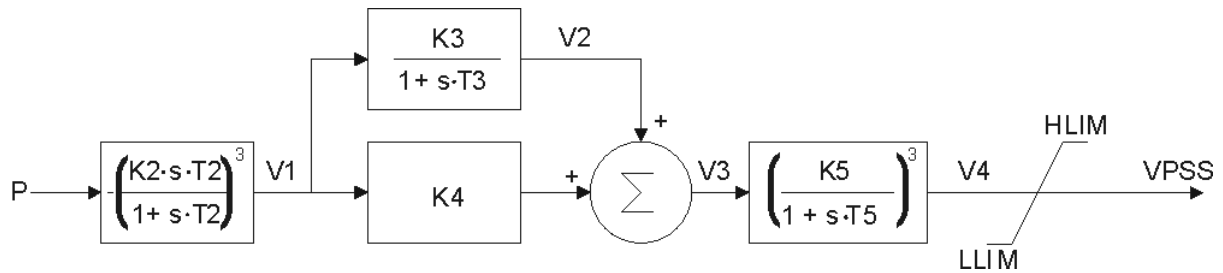

Parameters

NAME	Type	Description
K2	PU	Gain
T2	Seconds	Time constant
K3	PU	Gain
T3	Seconds	Time constant
K4	PU	Gain
K5	PU	Gain
T5	Seconds	Time constant
HLIM	PU	PSS output limit

Notes

Equivalent model in CIM/CGMES:

- No CIM/CGMES model

PSS - STAB3

Power Sensitive Stabilizing Unit.

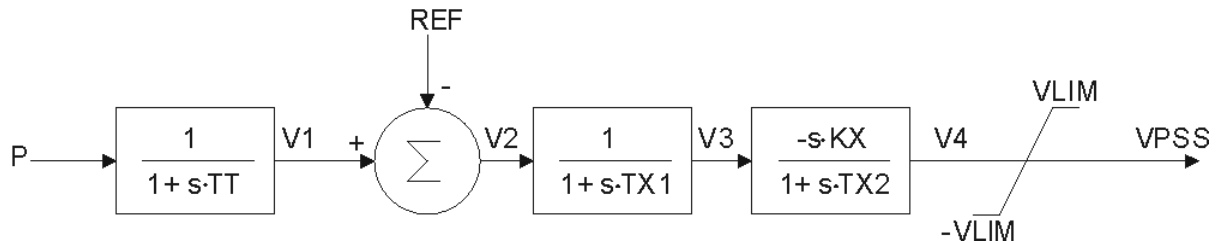

Parameters

NAME	Type	Description
TT	Seconds	Time constant
TX1	Seconds	Time constant
KX	PU	Gain
TX2	Seconds	Time constant
VLIM	PU	PSS output limit

Notes

Equivalent model in CIM/CGMES:

- No CIM/CGMES model

PSS - STAB4

Power Sensitive PSS.

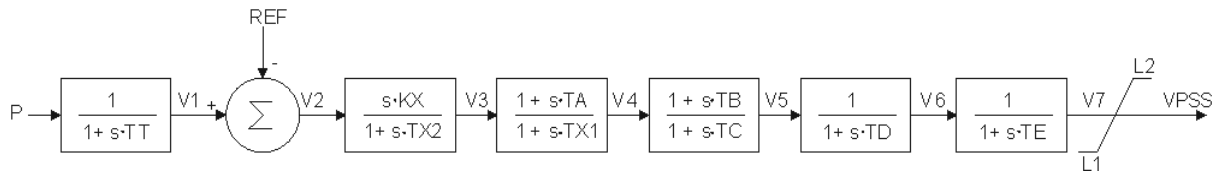

Parameters

NAME	Type	Description
TT	Second	Time constant
KX	PU	Gain
TX2	Second	Time constant
TA	Second	Time constant
TX1	Second	Reset time constant
TB	Second	Time constant
TC	Second	Time constant
TD	Second	Time constant
TE	Second	Time constant
L1	PU	Limiter
L2	PU	Limiter

Notes

Equivalent model in CIM/CGMES:

- PssSB4

PSS - STBSVC

WECC Supplementary Signal for Static var Compensator

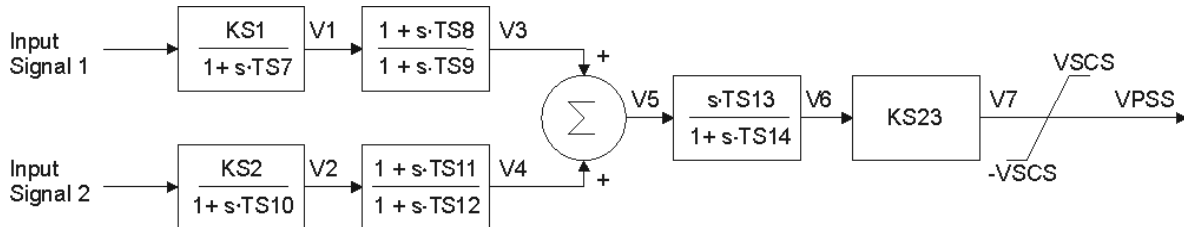

Parameters

NAME	Type	Description
SWS1	enum	Input 1, switch control 1 = PMECH, Accelerating power from remote machine (pu) is used as input 1 2 = P, Electrical power from a branch (pu) is used as input 1
SWS2	enum	Input 2, switch control 0 = No signal bus (pu) is used as input 2 1 = VT, Bus voltage (pu) is used as input 2 2 = VARs from SVC to system (pu) is used as input 2 3 = Current from SVC to system (pu). is used as input 2
KS1	PU	Input 1 Gain
KS2	PU	Input 2 gain
TS7	Seconds	Time constant
TS8	Seconds	Time constant
TS9	Seconds	Time constant
TS10	Seconds	Time constant
TS11	Seconds	Time constant
TS12	Seconds	Time constant
TS13	Seconds	Time constant
TS14	Seconds	Time constant
KS23	PU	Main gain
VSCS	PU	PSS output limit

Notes

Equivalent model in CIM/CGMES:

- No CIM/CGMES model

PSS - ST2CUT

Stabilizing Model with Dual-Input Signals

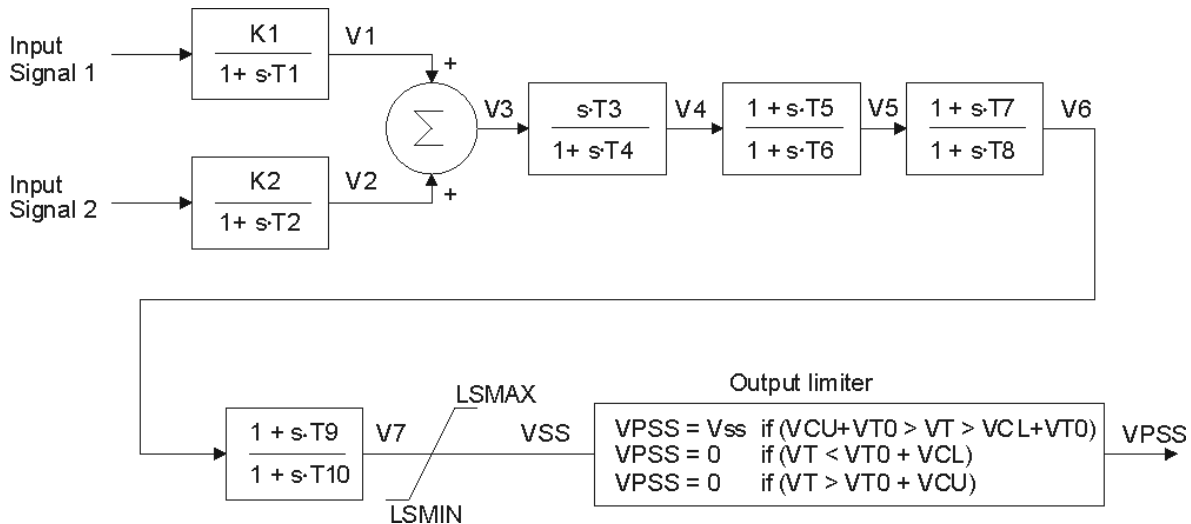

Parameters

NAME	Type	Description
SWS1	enum	Input 1, switch control 1 = W-1, Rotor speed deviation (pu) is used as input 2 = Frequency deviation at bus (pu) is used as input (Currently in NEPLAN as W-1, no remote frequency is implemented, but reserved for futur version) 3 = P, Electrical active power (pu) is used as input 4 = PMECH, Acceleration power (pu). is used as input 5 = VT, Bus Voltage (pu) is used as input 6 = dVT, Derivative of pu bus voltage. is used as input
SWS2	enum	Input 2, switch control 1 = W-1, Rotor speed deviation (pu) is used as input 2 = Frequency deviation at bus (pu) is used as input (Currently in NEPLAN as W-1, no remote frequency is implemented, but reserved for futur version) 3 = P, Electrical active power (pu) is used as input 4 = PMECH, Acceleration power (pu). is used as input 5 = VT, Bus Voltage (pu) is used as input 6 = dVT, Derivative of pu bus voltage. is used as input
K1	PU	Input 1 gain
T1	Seconds	Input 1 time constant
K2	PU	Input 2 gain
T2	Seconds	Input 2 time constant
T3	Seconds	Time constant
T4	Seconds	Time constant
T5	Seconds	Time constant
T6	Seconds	Time constant
T7	Seconds	Time constant
T8	Seconds	Time constant
T9	Seconds	Time constant
T10	Seconds	Time constant
LSMAX	PU	PSS output maximum limit
LSMIN	PU	PSS output minimum limit
VCL	PU	Cutoff limiter
VCU	PU	Cutoff limiter

Parameters Range:

$$0 \leq T_1 \leq 10$$

$$0 \leq T_8 \leq 10$$

$0 \leq T_2 \leq 10$
 $0 < T_3 \leq 10$
 $0.03 < T_4 \leq 10$
 $0 \leq T_5 < 10$
 $0 \leq T_6 < 2$
 $0 \leq T_7 \leq 10$

$0 \leq T_9 \leq 10$
 $0 \leq T_{10} < 2$
 $0 < LSMAX < 0.3$
 $-0.3 < LSMIN < 0$
 $0 \leq VCU < 1.25$
 $-0.1 \leq VCL < 1.0$

Notes

VT is the terminal voltage at bus
VT0 is the initial terminal voltage at bus

Equivalent model in CIM/CGMES:
- PssWECC