



NEPLAN AG
Oberwachtstrasse 2
8700 Küsnacht ZH
Switzerland

Phone: +41 44 914 36 66
Fax :+41 44 991 19 71

www.neplan.ch
bcp@neplan.ch

Wind Turbine Models

IEC 61400-27-1

Contents

1. General	2
2. Model Configuration	3
2.1. Type 1	3
2.2. Type 2	6
2.3. Type 3	7
2.4. Type 4	11
References	17
APPENDIX A , INPUT of Blocks/Functionalities	18
A1. Parameters for WT type 1A.....	18
A2. Parameters for WT type 1B.....	18
A3. Parameters for WT type 2	19
A4. Parameters for WT type 3A	20
A5. Parameters for WT type 3B.....	24
A6. Parameters for WT type 4A	24
A7. Parameters for WT type 4B.....	27
List of Figures.....	29
List of Tables	30

Wind Turbine Models IEC 61400-27-1

1. General

This document describes the usage of the wind turbine generator (WTG) by NEPLAN power systems analysis tools on the base of [1].

Four different types will be described by splitting in nine models. All parts of the dynamic models are listed in the following Tab. 1.

Block/Functionality	WT1A	WT1B	WT2	WT3A	WT31A	WT3B	WT4A	WT41A	WT4B
Generator System (Induction Gen.)	✓	✓	✓						
Generator System Type 3A				✓	✓				
Generator System Type 3B						✓			
Generator System Type 4							✓	✓	✓
Aerodynamic (Const. Aero Torque)	✓								
Aerodynamic (One-dimensional aero model)				✓		✓			
Aerodynamic (Two-dimensional aero model)					✓				
Control (P control type 3)				✓	✓	✓			
Control (P control type 4A)							✓	✓	
Control (P control type 4B)									✓
Control (Q control mode)				✓	✓	✓	✓	✓	✓
Constant Q limitation model				✓	✓	✓	✓	✓	✓
QP and QU limitation model								✓	
Control (Pitch control power model)		✓	✓						
Control (Pitch angle control model)				✓	✓	✓			
Control (Rotor resistance control model)			✓						
Mechanical (Two mass)	✓	✓	✓	✓	✓	✓			✓
Control (Current limitation model)				✓	✓	✓	✓	✓	✓
Reference frame rotation model				✓	✓	✓	✓	✓	✓
Grid Protection	✓	✓	✓	✓	✓	✓	✓	✓	✓

Tab. 1: CGMES Blocks/Functionalities Overview

2. Model Configuration

In this chapter the configuration of four different WT types with their correspondent models will be described for the dynamic test systems.

2.1. Type 1

The WT type 1 (Fig. 1) is described by an asynchronous generator directly connected to the grid (without power converter). There are two subtypes, WT1A and WT1B: WT1A includes a fixed pitch angle, WT1B includes UVRT pitch angle control.

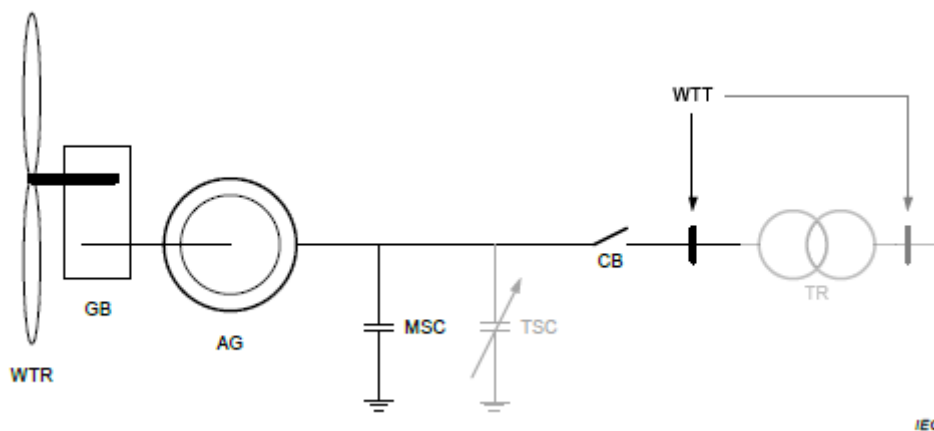

Fig. 1: Main electrical and mechanical components of type 1 WTs [1].

The NEPLAN system descriptions are in Fig. 2 and Fig. 4, respectively for WT1A and WT1B, some results are shown in Fig. 3 and Fig. 5.

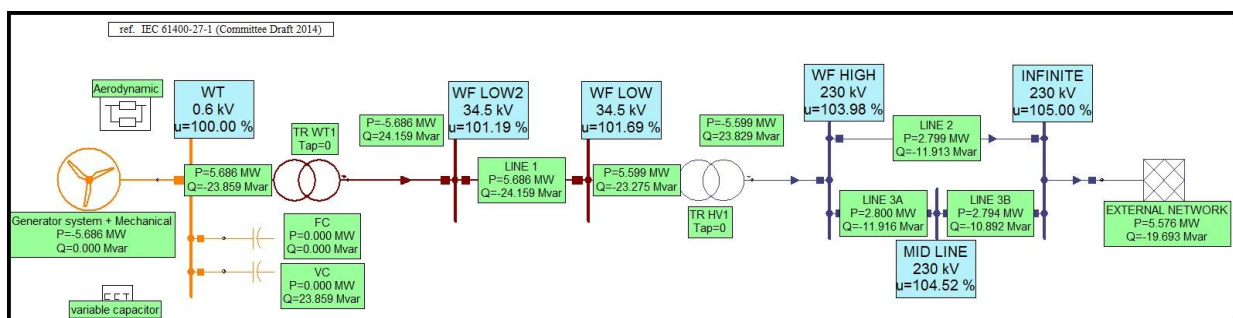

Fig. 2: System description WT1A

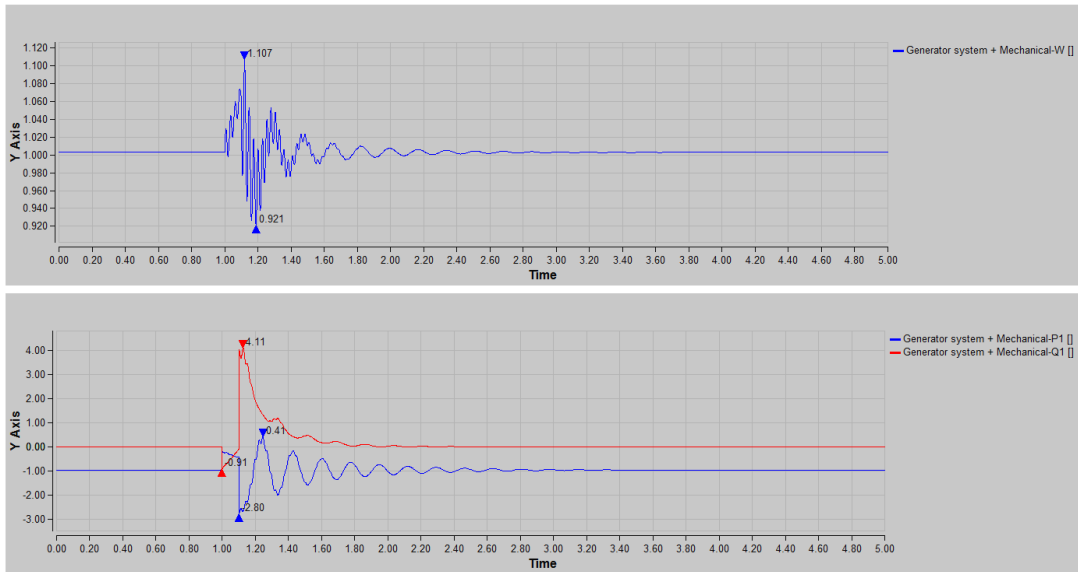

Fig. 3: Some results by WT1A simulation

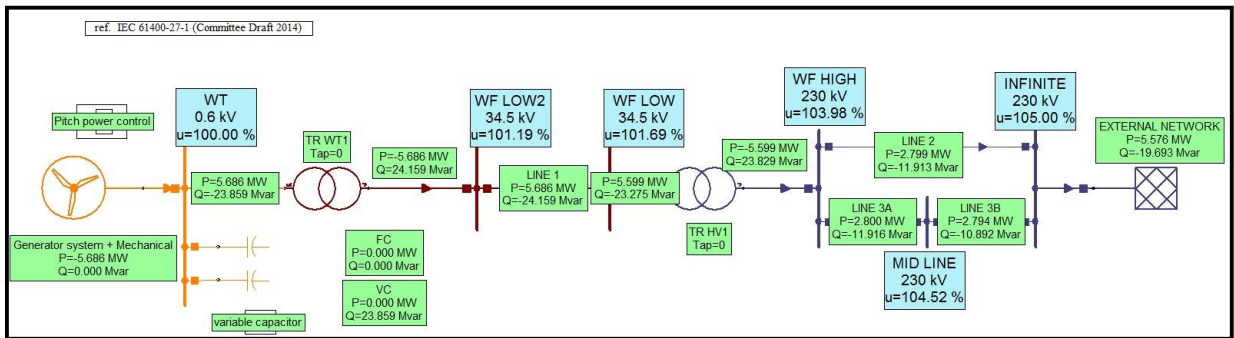

Fig. 4: System description WT1B

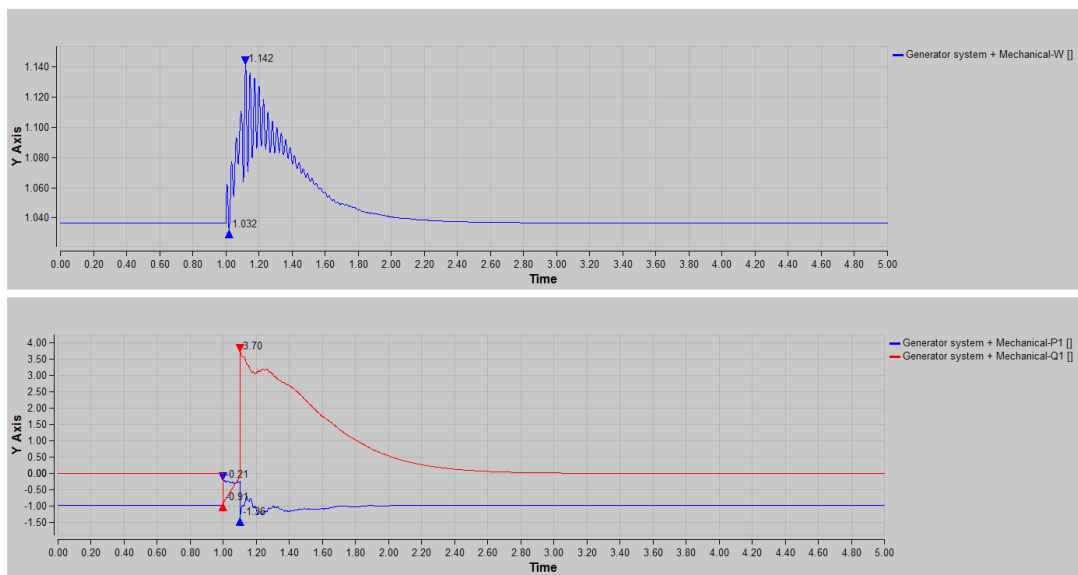

Fig. 5: Some results by WT1B simulation

Output variables for **RESULTS of WT1A** from Fig. 6:

- Active and reactive power of generator system;
- P_aereo;
- Generator speed (Wgen) and Mechanical speed (WTR).

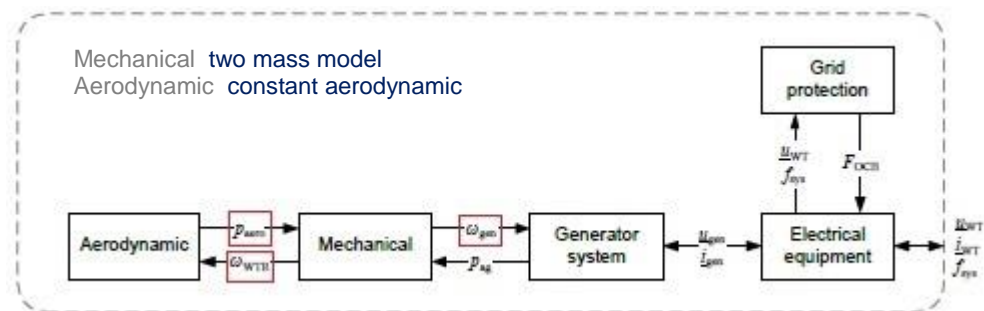

Fig. 6: Modular structure for the type 1A WT model [1].

Output variables for **RESULTS of WT1B** from Fig. 7:

- Active and reactive power of generator system;
- Pitch control power;
- Generator speed (Wgen) and Mechanical speed (WTR).

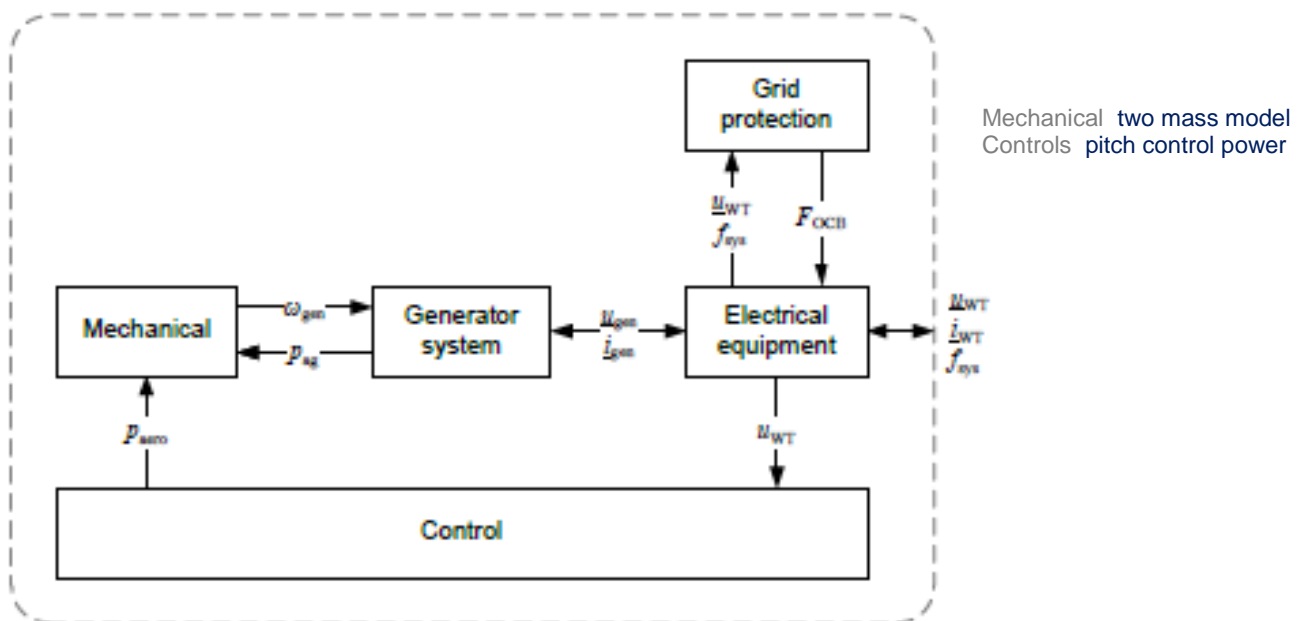

Fig. 7: Modular structure for the type 1B WT model [1].

2.2. Type 2

The type 2 WT is similar to a type 1 WT in many aspects. In type 2 the turbine is equipped with a variable rotor resistance (VRR) and normally with pitch power control, it is shown in Fig. 8.

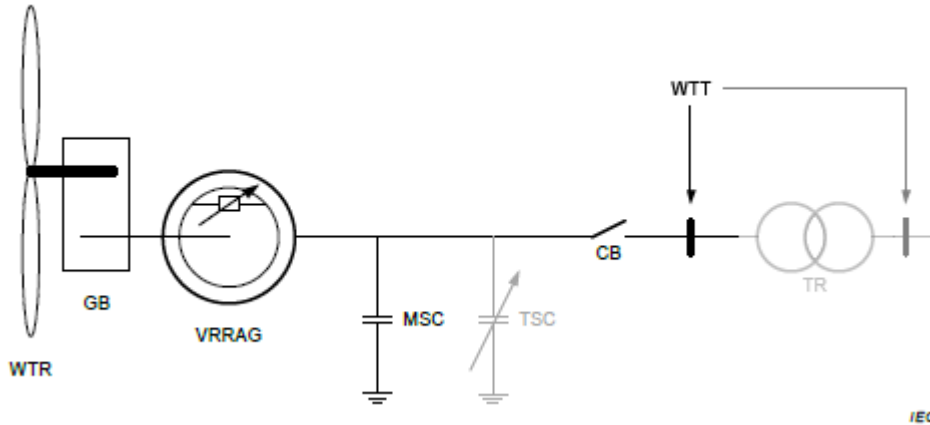

Fig. 8: Main electrical and mechanical components of type 2 WTs [1].

The NEPLAN system is shown in Fig. 9 and some results are shown in Fig. 10.

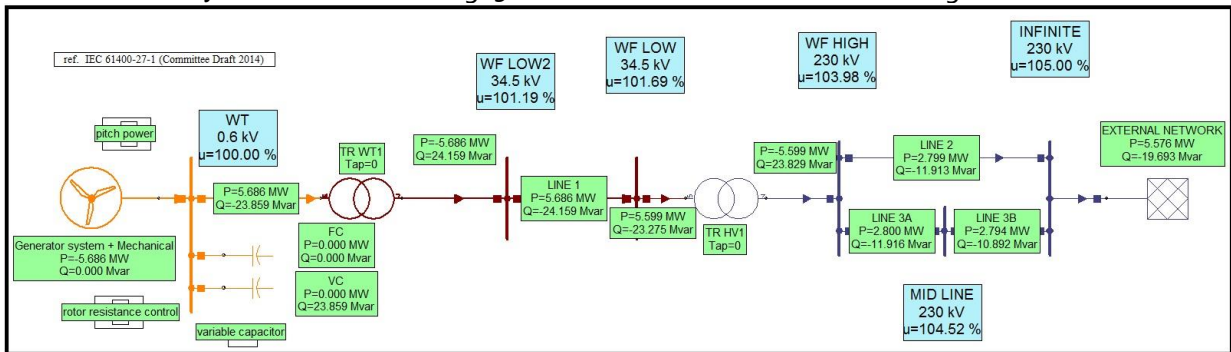

Fig. 9: System description type 2 WT

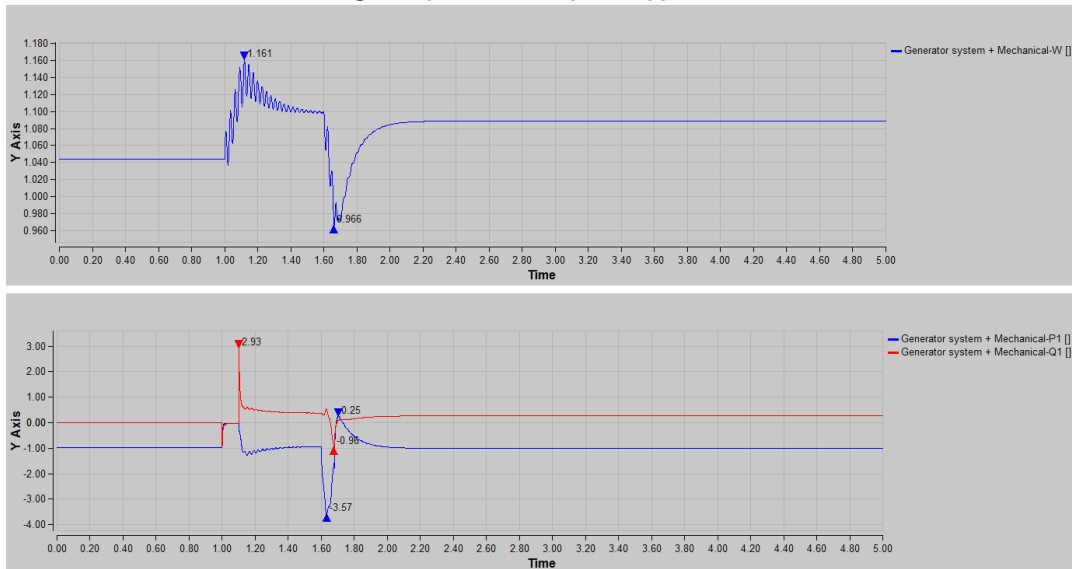

Fig. 10: Some results by WT2 simulation.

Output variables for **RESULTS of WT2** from Fig. 11:

- Active and reactive power of generator system;
- Pitch control power;
- Generator speed (ω_{gen}) and Mechanical speed (ω_{tr});
- Rotor resistance control (r_{rot}).

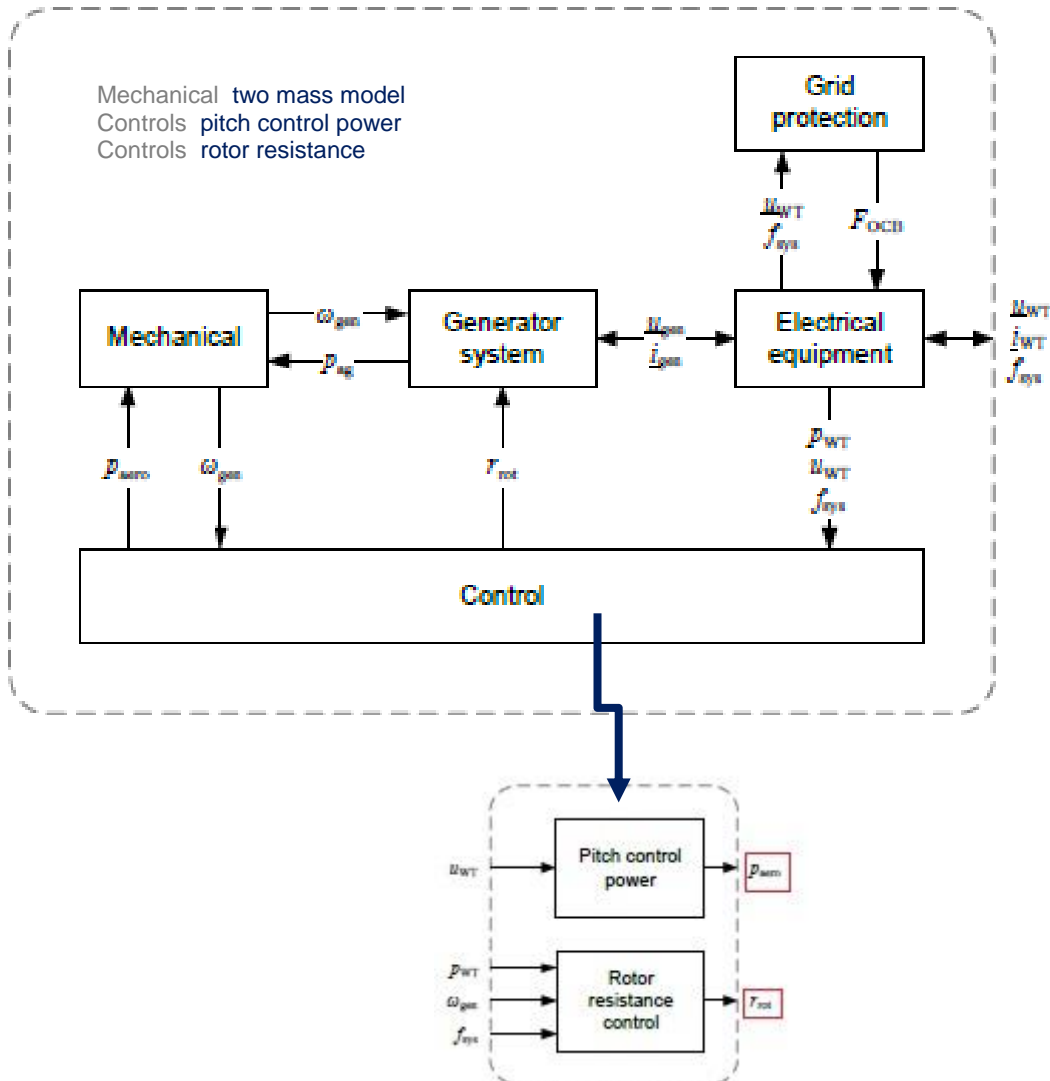

Fig. 11: Modular structure for the type 2 WT model [1].

2.3. Type 3

The type 3 WT (Fig. 12) uses a doubly fed asynchronous generator (DFAG), where the stator is directly connected to the grid and the rotor is connected through a back-to-back power converter. There are two subtypes, WT3a and WT3b: WT3a is without crowbar protection, WT3b is with crowbar protection.

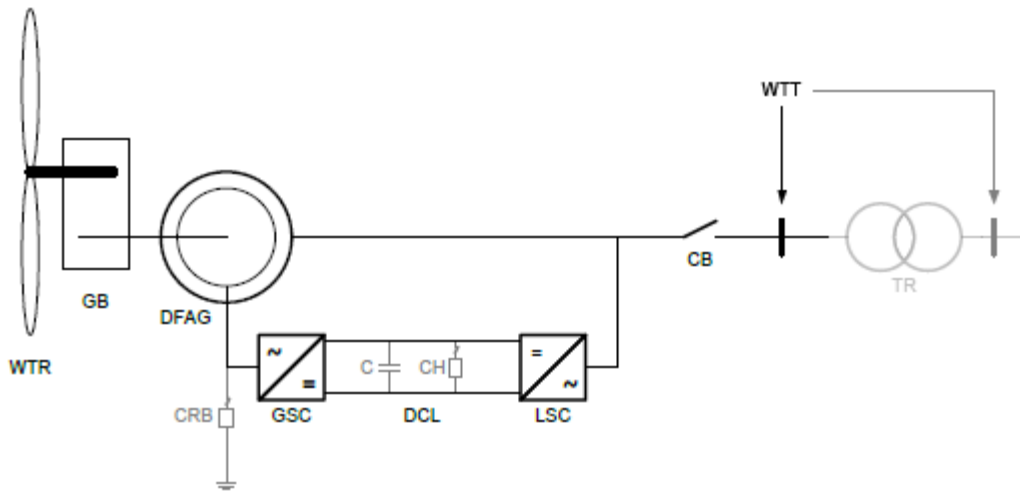

Fig. 12: Main electrical and mechanical components of type 3 WTs [1].

For type WT3a two different cases are considered, WT3A and WT31A. The difference is in the aerodynamic torque model: WT3A includes one dimensional aerodynamic model, WT31A the two dimensional one.

The NEPLAN systems are shown in Fig. 13 and Fig. 14 respectively for WT3A and WT31A. Some results are shown in Fig. 15.

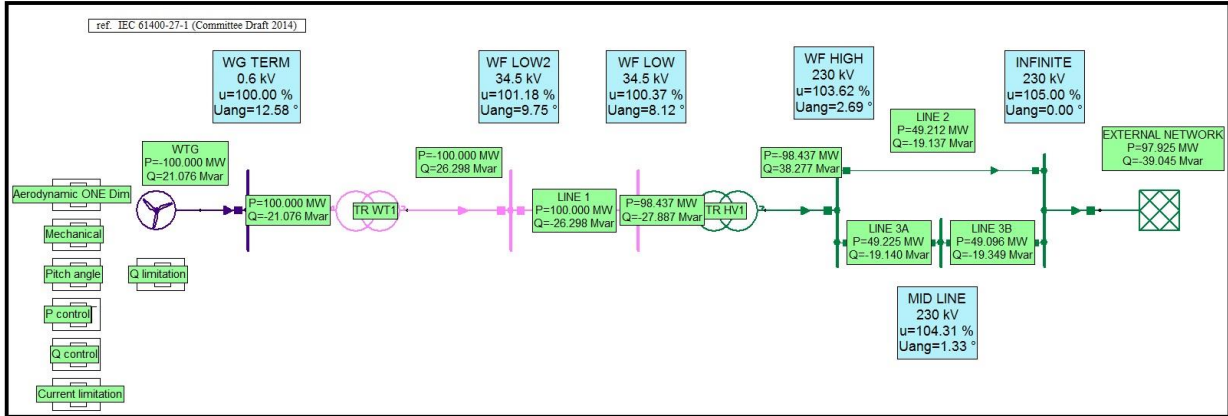

Fig. 13: System description type 3A WT.

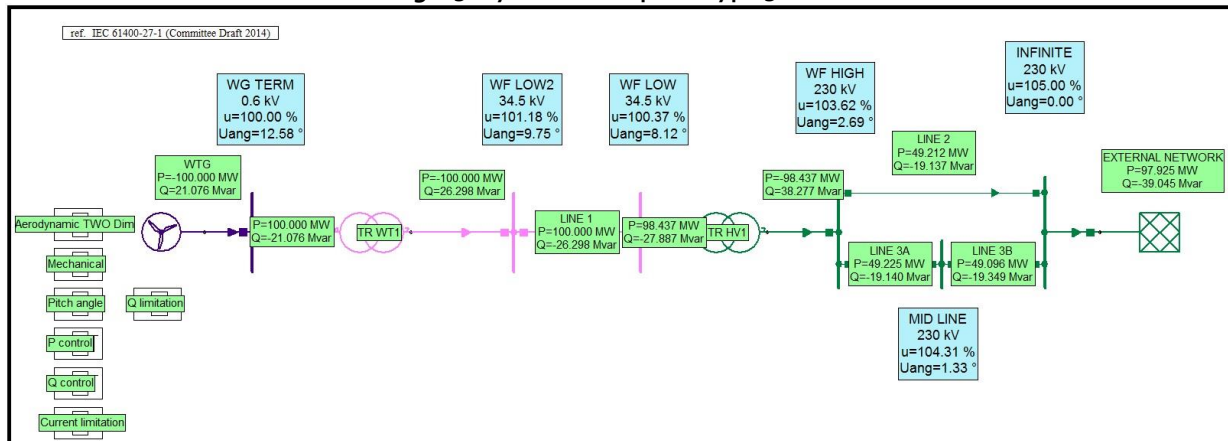

Fig. 14: System description type 31A WT.

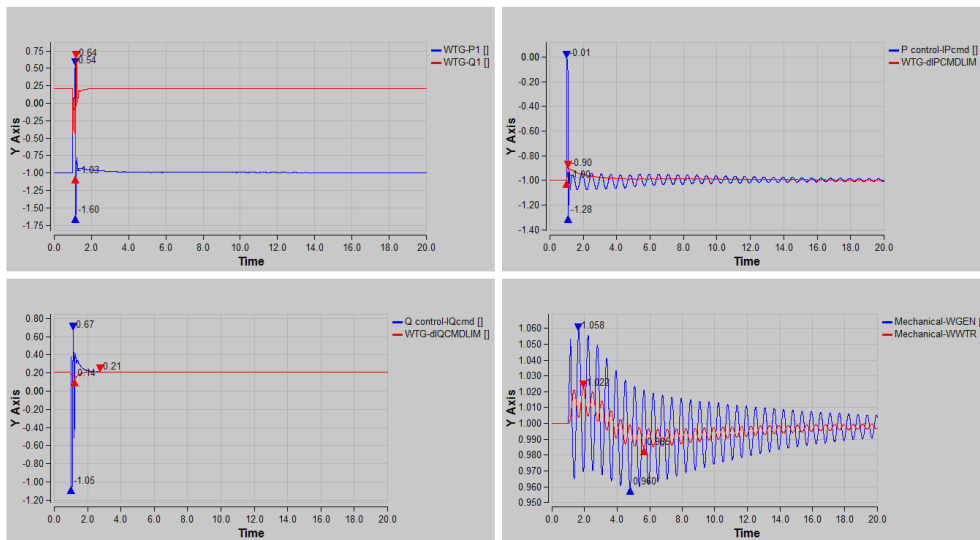

Fig. 15: Some results by WT3A simulation.

The NEPLAN system of type WT3B is shown in Fig. 16 and some results are shown in Fig. 17.

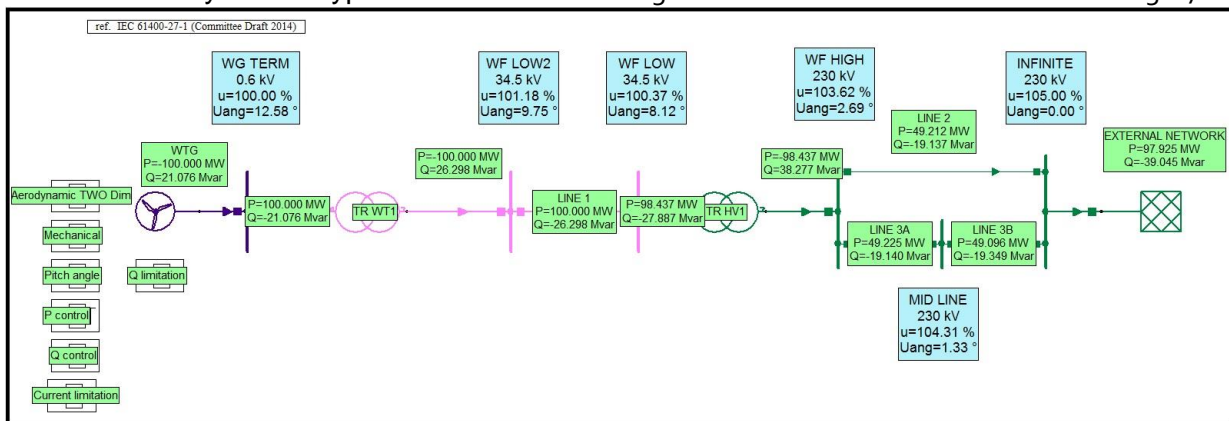

Fig. 16: System description type 3b WT.

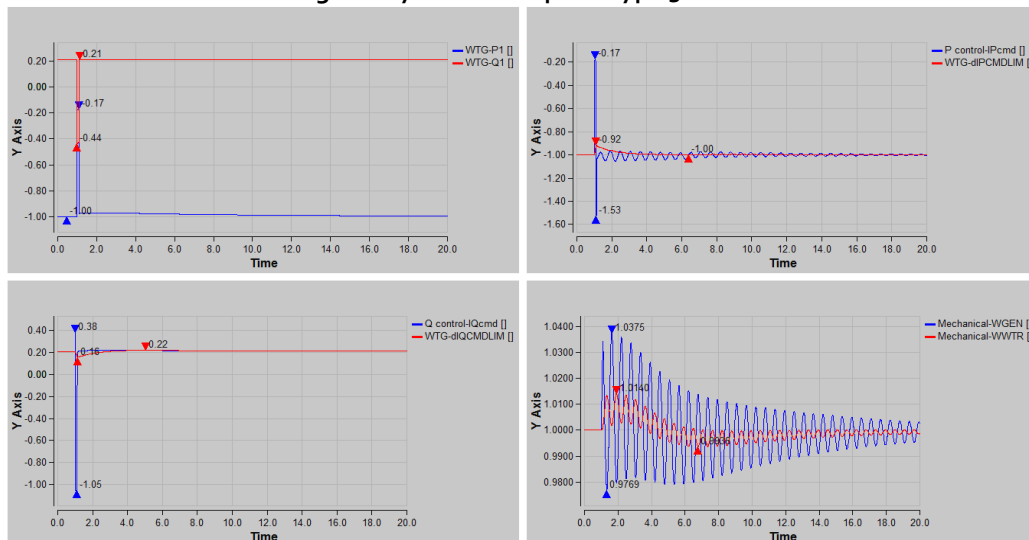

Fig. 17: Some results by WT3B simulation.

Output variables for **RESULTS of WT3a** from Fig. 18 and Fig. 19 :

- Active and reactive power of generator system;
- Aerodynamic one dimension (P_{aero});
- pitch angle (Θ);
- Generator speed (ω_{gen}) and Mechanical speed (ω_{WTR});
- Active power control (I_{pcmd} and I_{qcmd}).

Output variables for **RESULTS of WT31a** from Fig. 18 and Fig. 19 :

- Active and reactive power of generator system;
- Aerodynamic two dimension (P_{aero});
- Pitch angle (Θ);
- Generator speed (ω_{gen}) and Mechanical speed (ω_{WTR});
- Active power control (I_{pcmd} and I_{qcmd}).

Output variables for **RESULTS of WT3b** from Fig. 18 and Fig. 19 :

- Active and reactive power of generator system;
- Aerodynamic one dimension (P_{aero});
- Pitch angle (Θ);
- Generator speed (ω_{gen}) and Mechanical speed (ω_{WTR});
- Active power control (I_{pcmd} and I_{qcmd}).

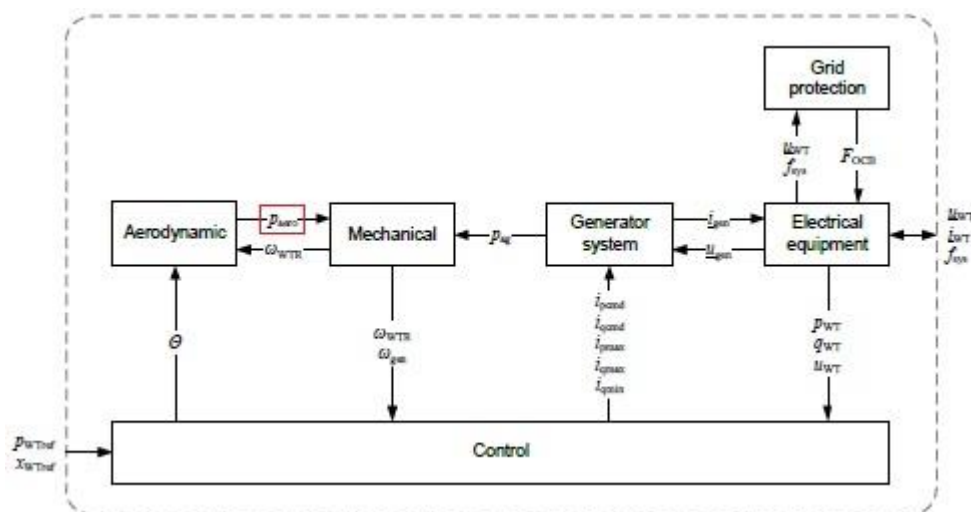

Fig. 18: Modular structure for the type 3 WT model [1].

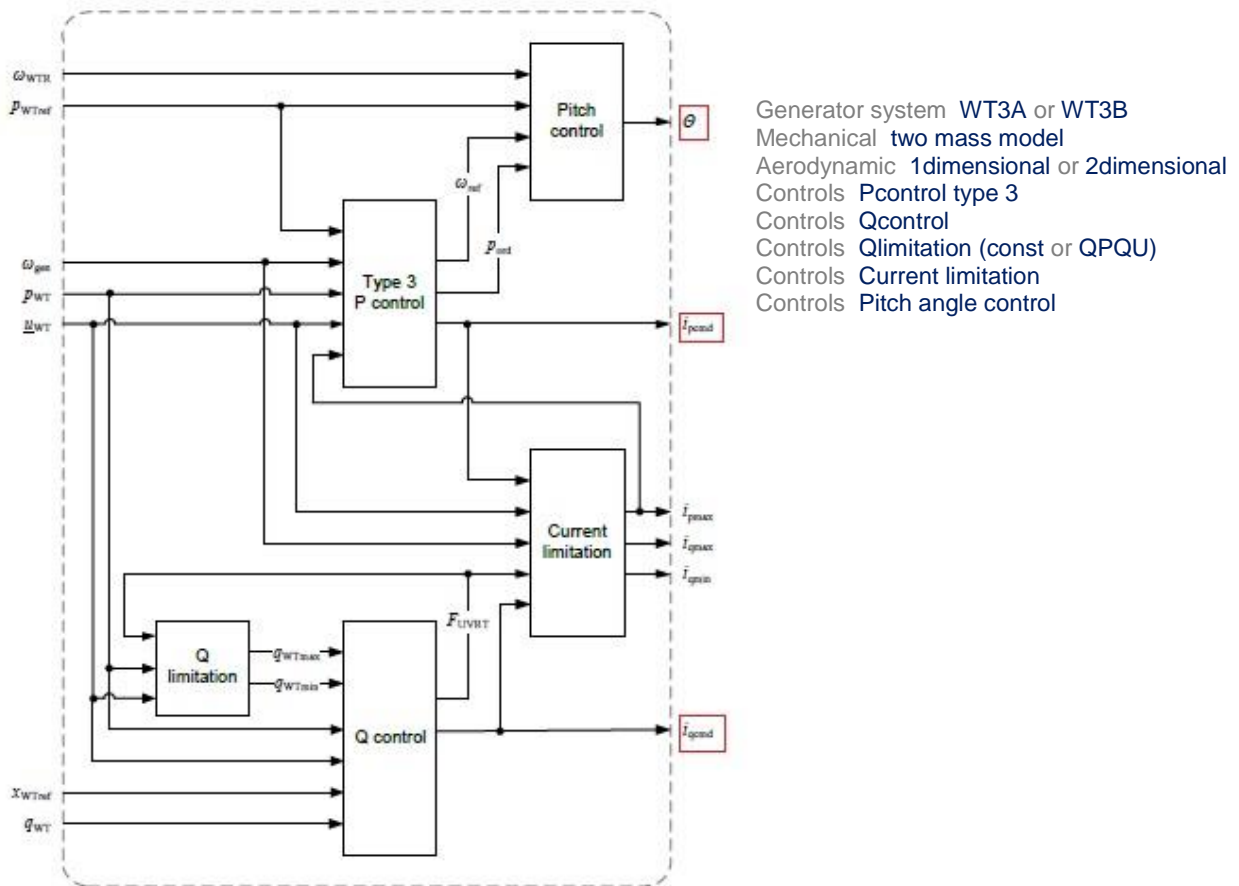

Fig. 19: Modular structure for the type 3 WT control model [1].

2.4. Type 4

The WT type 4 (Fig. 20) uses either synchronous generators or asynchronous generators, and they are connected to the grid through a full scale power converter. There are two subtypes, WT4a and WT4b: in WT4a the aerodynamic and mechanical parts are neglected, in WT4b the two mass mechanical model is included, but assuming constant aerodynamic torque.

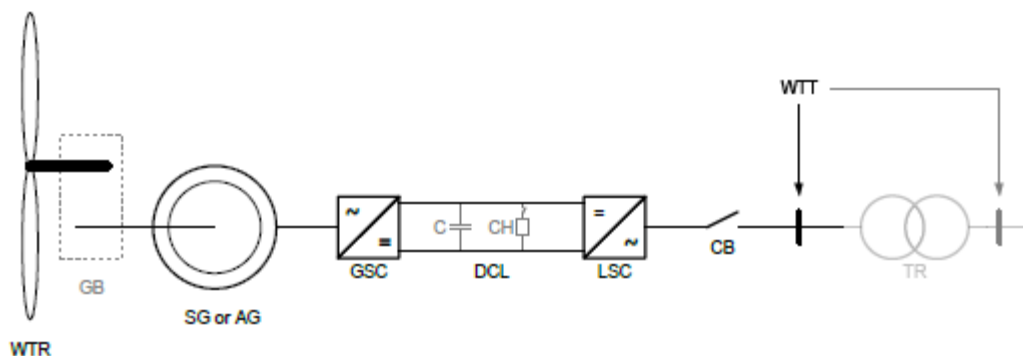

Fig. 20: Main electrical and mechanical components of type 4 WTs [1].

For type WT4A two different cases are considered, WT4A and WT41A. The difference is in the Q limitation control: WT4A uses constant Q limitation control, WT41A the QPQU Q limitation control.

The NEPLAN systems are shown in Fig. 21 and Fig. 22 respectively for WT4A and WT41A. Some results are shown in Fig. 23.

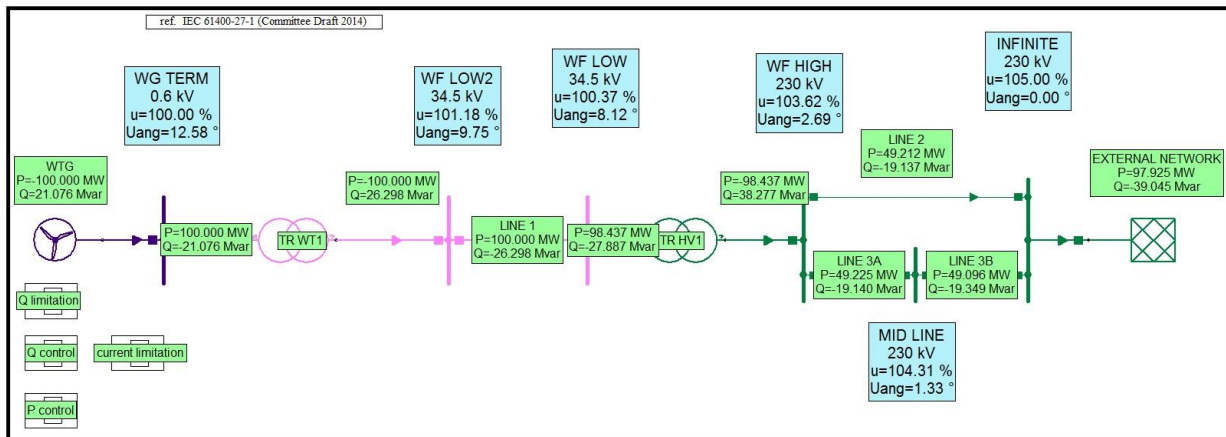

Fig. 21: System description type 4A WT.

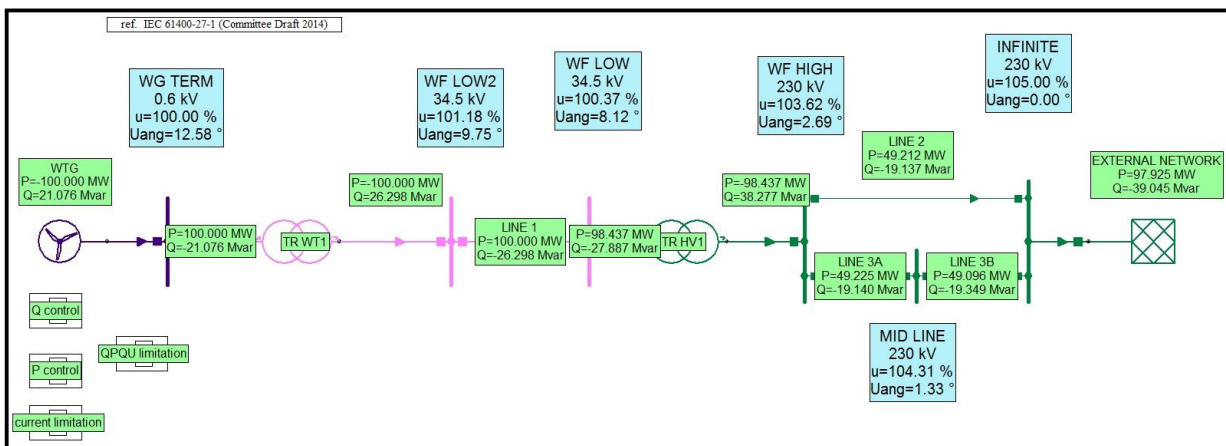

Fig. 22: System description type 41A WT.

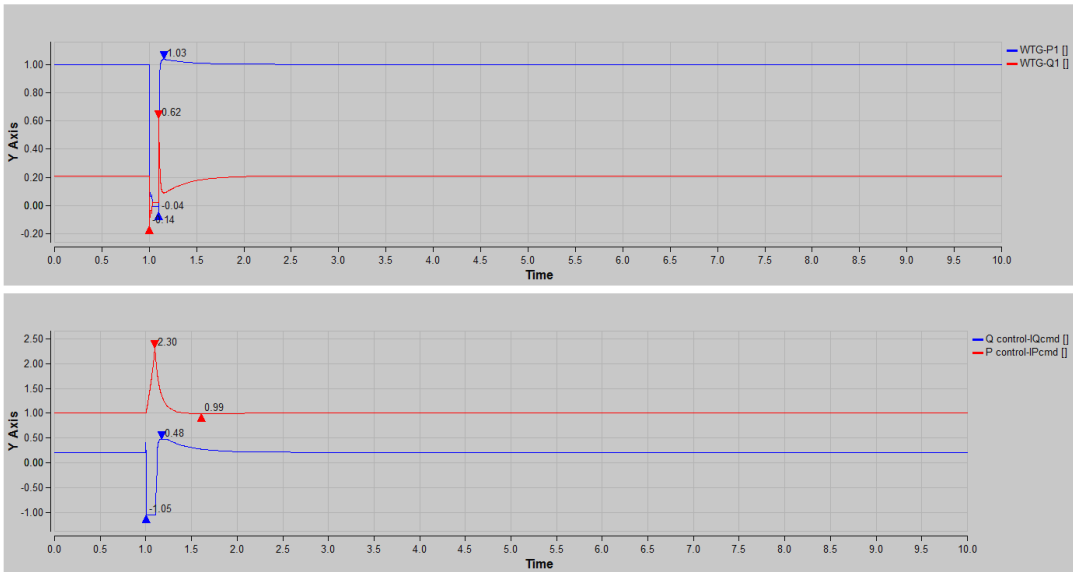

Fig. 23: Some results by WT4A simulation.

The NEPLAN system of type WT4B is shown in Fig. 24 and some results are shown in Fig. 25.

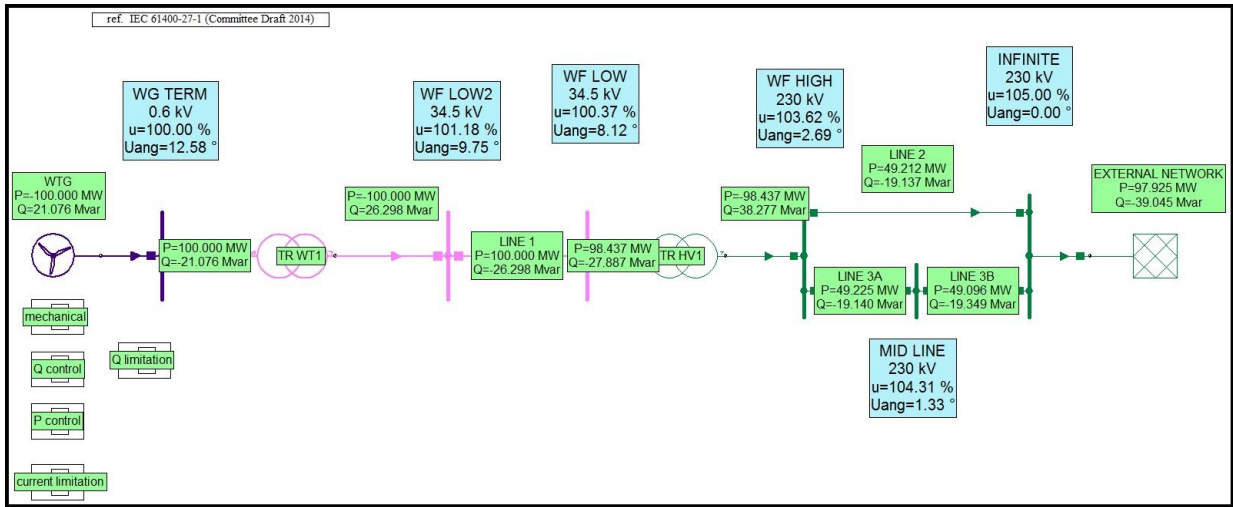

Fig. 24: System description type 4B WT.

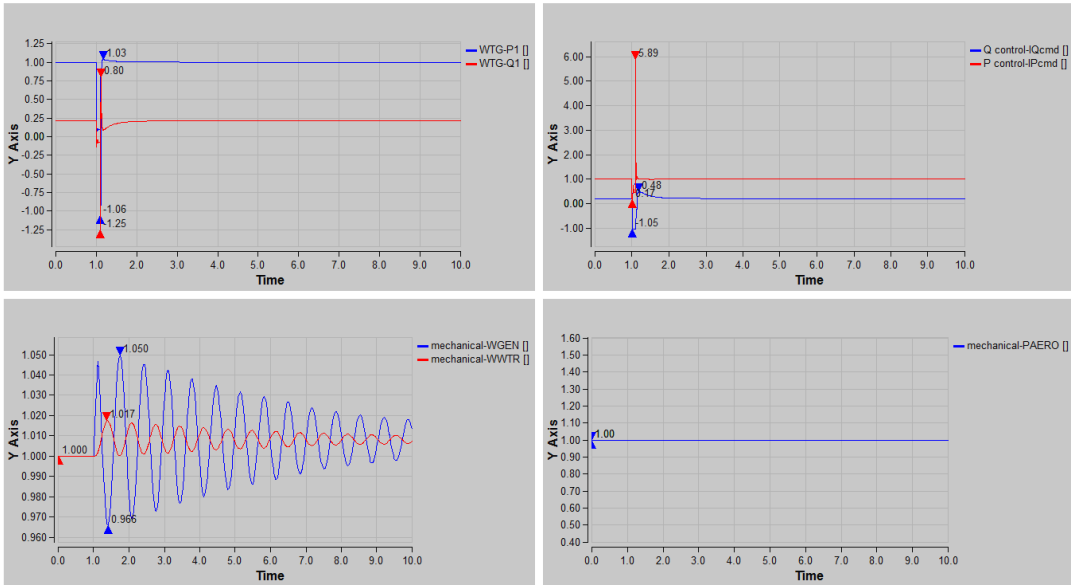

Fig. 25: Some results by WT4B simulation.

Output variables for **RESULTS of WT4a** from Fig. 26 and Fig. 27:

- Active and reactive power of electrical equipment;
- Reactive power limitation control output (QWTmax and QWTmin);
- Active power control (Ipcmd and Iqcmd).

Output variables for **RESULTS of WT41a** from Fig. 26 and Fig. 27:

- Active and reactive power of electrical equipment;
- QPQU limitation control output (QWTmax and QWTmin);
- Active power control (Ipcmd and Iqcmd).

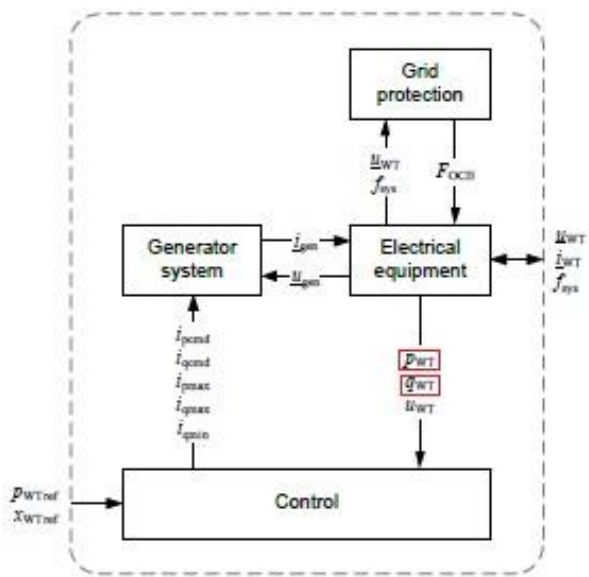
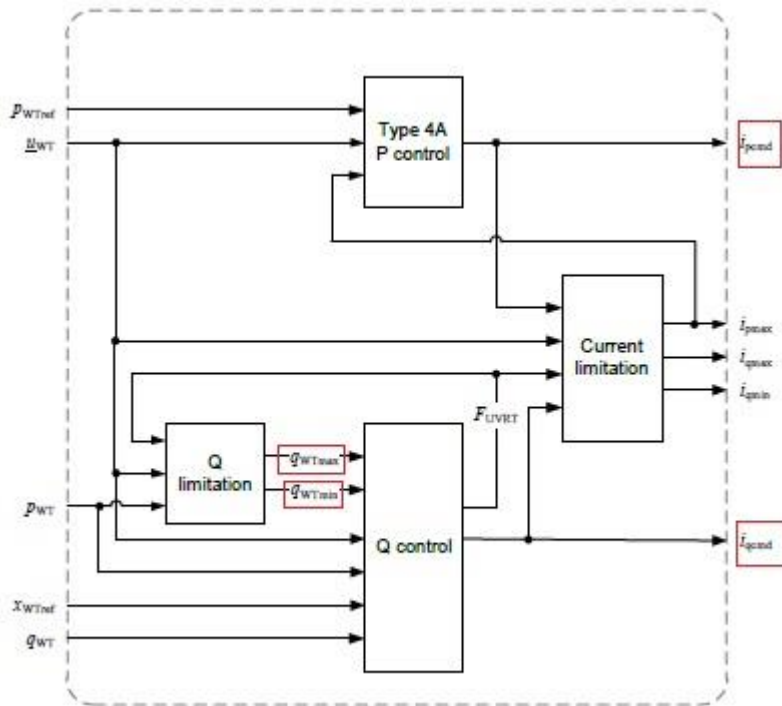

Fig. 26: Modular structure for the type 4a WT model [1].



Generator system WT4
 Controls P control type 4A
 Controls Q control
 Controls Q limitation (const or QPQU)
 Controls Current limitation

Fig. 27: Modular structure for the type 4a control model [1].

Output variables for **RESULTS of WT4b** from Fig. 28 and Fig. 29:

- Active and reactive power of electrical equipment,
- P_aero,
- Generator speed (Wgen) and mechanical speed (WTR),
- Active power control (Ipcmd and Iqcmd)

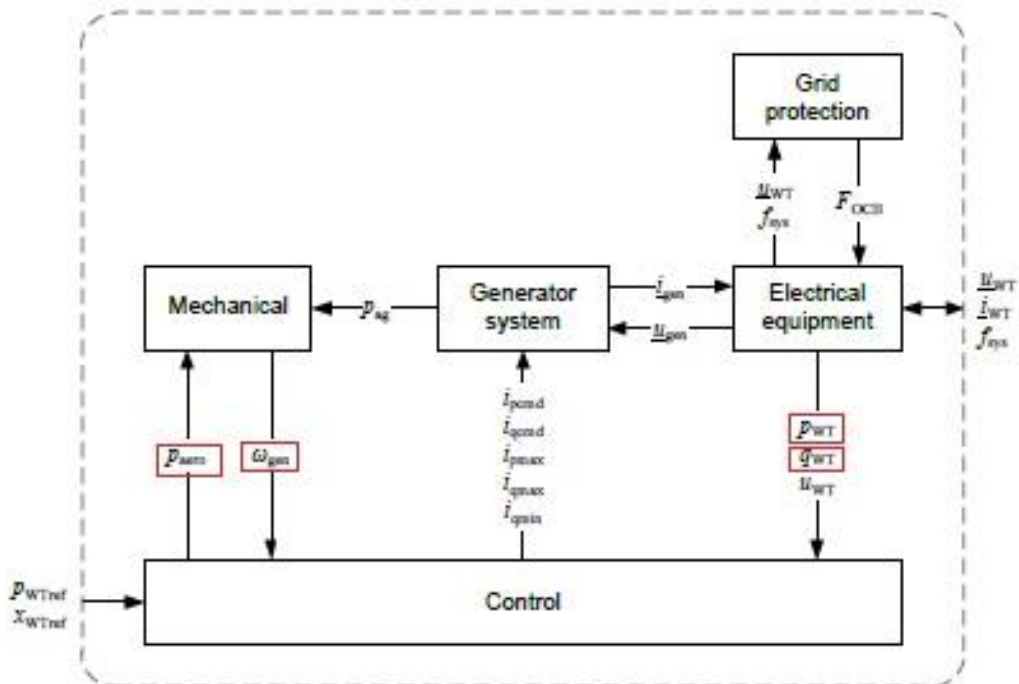
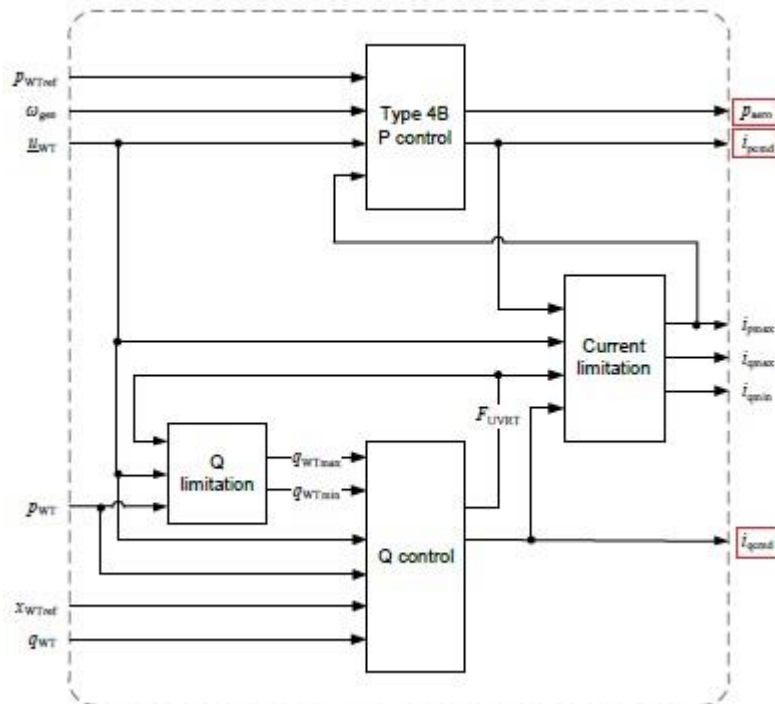

Fig. 28: Modular structure for the type 4b WT model [1].



Generator system WT4
 Mechanical two mass model
 Controls Pcontrol type 4B
 Controls Qcontrol
 Controls Qlimitation (const or QPQU)
 Controls Current limitation

Fig. 29: Modular structure for the type 4b control model [1].

References

- [1] IEC 61400-27-1 Electrical Simulation Models for Wind Power Generation; Final Draft International Standard, 2014.

APPENDIX A , INPUT of Blocks/Functionalities

A1. Parameters for WT type 1A

In this paragraph the input parameters of Blocks/Functionalities for the WT type 1A are indicated to simulate the WG27, IEC 61400-27-1 systems by using NEPLAN software tool. The following input parameters in Tab. 2 are used also for Type 1B.

Mechanical Two mass	
cdrt	1.5
hgen	0.0625
hwtr	0.4375
kdr	17.27

Tab. 2: Values of Mechanical (Two mass) parameters for WT type 1.

A2. Parameters for WT type 1B

The input parameters used for the Type 1B are equal than previous ones of WT Type 1A (paragraph A1). Only the following input parameter values (Tab.3) and its "WindLookupTableFunctionKind" (Tab. 4) are different:

Pitch control power	
dpmax	100
dpmin	-100
pmin	-100
pset	1
t1	0.05
tr	0.01
uuvrt	0.1

Tab.3: Values of Pitch control power model parameters.

enum tduwt	
TDUWT1	0.9
TDUWT2	0.93
TDUWT3	0.96
TDUWT4	0.99
TDUWT5	1.2
UWT1	0.8
UWT2	0.83
UWT3	0.86
UWT4	0.89
UWT5	0.92

Tab. 4: Values of WindLookupTableFunctionKind enum tduwt parameters for WT type 1B.

A3. Parameters for WT type 2

In this paragraph the input parameters of Blocks/Functionalities for the WT type 2 are indicated to simulate the WG27, IEC 61400-27-1 systems by using NEPLAN software tool.

Mechanical Two mass	
cdrt	1.5
hgen	0.0625
hwtr	0.4375
kdrtr	17.27

Tab. 5: Values of Mechanical (Two mass) parameters for WT type 2.

Pitch control power	
dpmax	100
dpmin	-100
pmin	-100
pset	1
t1	0.05
tr	0.01
uuvrt	0.1

Tab. 6: Values of Pitch control power model parameters.

enum tduwt	
TDUWT1	0.9
TDUWT2	0.93
TDUWT3	0.96
TDUWT4	0.99
TDUWT5	1.2
UWT1	0.8
UWT2	0.83
UWT3	0.86
UWT4	0.89
UWT5	0.92

Tab. 7: Values of WindLookupTableFunctionKind enum tduwt parameters for WT type 2.

Rotor resistance control	
kirr	100
komegafilt	1
kpfilt	1
kpr	0.01
rmax	0.0977
rmin	0.0061
tomegafiltr	0.05
tpfiltr	0.05

Tab. 8: Values of Rotor resistance control parameters.

enum prr	
SLP1	0
SLP2	0.0054
SLP3	0.02
SLP4	0.04
SLP5	0.1
POW1	0
POW2	0.0217
POW3	0.8988
POW4	0.9652
POW5	0.9652

Tab. 9: Values of WindLookupTableFunctionKind enum prr parameters.

A4. Parameters for WT type 3A

In this paragraph the input parameters of Blocks/Functionalities for the WT type 3A are indicated to simulate the WG27, IEC 61400-27-1 systems by using NEPLAN software tool. The following input parameters are used also for Type 3B, the different input values are shown in paragraph A5 (Tab. 24 and Tab. 25).

Wind Turbine Type 3	
djqmax	9999
xs	0.4
dipmax	9999

Tab. 10: Values of WindTurbineType3 parameters for type 3A.

Generator System Type 3A	
kpc	40
tic	0.02

Tab. 11: Values of Generator System Type 3A parameters.

Aerodynamic One-dimensional	
ka	0.1
thetaomega	0

Tab. 12: Values of Aerodynamic One-dimensional parameters.

Aerodynamic Two-dimensional	
thetav2	25
thetazero	0
omegazero	1
pavail	0
dpv1	1.4
dptheta	-0.03
dpomega	-0.22

Tab. 13: Values of Aerodynamic Two-dimensional parameters.

enum omegap	
WP1	0.76
WP2	0.76
WP3	0.86
WP4	0.94
WP5	1
WP6	1
PWP1	0
PWP2	0.35
PWP3	0.36
PWP4	0.46
PWP5	0.56
PWP6	1

Tab. 14: Values of WindLookupTableFunctionKind enum omegap parameters.

Control P type 3	
mpuvrt	1
zeta	0.4
dthetamax	0.25
dprefmax	0.3
kdt	1.56
kip	4
kpp	8
dthetamaxuvrt	999
dprefmin	-0.3
omegaoffset	0.02
pdtmax	0.15
dpmax	999
thetaemin	0.001
thetauscale	1
wtd	11.3
updip	0.9
tpord	0.01
udvs	0.15
tufilt3	0.01
tpfilt3	0.01
tomegafilt3	0.04
tdvs	0.05
twref	4.5

Tab. 15: Values of Control P type 3 parameters.

Constant Q limitation	
qmax	0.8
qmin	-0.8

Tab. 16: Values of Constant Q limitation parameters for WT type 3.

Reference frame rotation model	
upll1	999
upll2	0.13
tpll	0.01

Tab. 17: Values of Reference frame rotation model parameters for WT type 3..

Control Q	
iqh1	1.05
iqmax	1.05
iqmin	-1.05
iqpost	0
kiq	0
kiu	0
kpq	1.1
kpu	2
kqv	2
rdroop	0.06
uref0	1
xdroop	0.01
uqdip	0.9
umin	0.9
udb1	0.9
udb2	1.1
umax	1.1
tqord	0.02
tpfiltq	0.01
tpost	0
tufiltq	0.01
windQcontrolModesType	1
windUVRTQcontrolModesType	2

Tab. 18: Values of Control Q parameters for WTs type 3.

Pitch angle control	
dthetamax	6
dthetamin	-4
kic	0
kiomega	15
kpc	0

kpomega	80
kpx	0.03
thetamax	35
thetamin	0
ttheta	0.25

Tab. 19: Values of Pitch angle control parameters.

Mechanical	
cdrt	1
hgen	1
hwtr	5
kdr	200

Tab. 20: Values of Mechanical (Two mass) parameters for WTs type 3.

Current limitation control	
mdfslim	0
mcpri	1
kpqu	20
imaxdip	1.3
upqumax	1.1
imax	1.3
tufiltcl	0.01

Tab. 21: Values of Current limitation control parameters for WTs type 3.

enum ipmax	
UWTT1_IPMAX	0
UWTT2_IPMAX	0.2
UWTT3_IPMAX	0.2
UWTT4_IPMAX	0.9
UWTT5_IPMAX	0.9
UWTT6_IPMAX	1.1
IPMAX1	0
IPMAX2	0
IPMAX3	1
IPMAX4	1
IPMAX5	1
IPMAX6	1.0001

Tab. 22: Values of WindLookupTableFunctionKind enum ipmax parameters for WTs type3.

enum iqmax	
UWTT1_IQMAX	0
UWTT2_IQMAX	0.2
UWTT3_IQMAX	0.3

UWTT4_IQMAX	0.9
UWTT5_IQMAX	0.91
UWTT6_IQMAX	1.1
IQMAX1	0
IQMAX2	0
IQMAX3	1
IQMAX4	1
IQMAX5	0.43
IQMAX6	0.35

Tab. 23: Values of WindLookupTableFunctionKind enum iqmax parameters for WTs type3.

A5. Parameters for WT type 3B

The input parameters used for the Type 3B are equal than previous ones of WT Type 3A (paragraph A4). Only the following parameter input values (Tab. 23 and Tab. 24) are different:

Wind TurbineType 3	
diqmax	0
xs	0.4
dipmax	100

Tab. 24: Values of WindTurbineType3 parameters for type 3B.

Generator System Type 3B	
mwtcwp	1
two	0
tg	10

Tab. 25: Values of Generator System Type 3B parameters.

A6. Parameters for WT type 4A

In this paragraph the input parameters of Blocks/Functionalities for the WT type 4A are indicated to simulate the WG27 system by using NEPLAN software tool.

Generator System Type 4	
dipmax	1
diqmin	-100
diqmax	100
tg	0.01

Tab. 26: Values of Generator System Type 4IEC parameters.

P control type 4A	
dpmax4a	1
tpordp4a	0.1
tufiltp4a	0.1

Tab. 27: Values of P control type 4A parameters

Constant Q limitation	
qmax	0.8
qmin	-0.8

Tab. 28: Values of Constant Q limitation parameters for WT type 4.

Reference frame rotation model	
upll1	999
upll2	0.13
tpll	0.01

Tab. 29: Values of Reference frame rotation model parameters for WT type 4.

Current limitation control	
mdfslim	0
mqpri	1
kpqu	20
imaxdip	1.3
upqumax	1.1
imax	1.3
tufiltcl	0.01

Tab. 30: Values of Current limitation control parameters for WT type 4.

enum ipmax	
UWTT1_IPMAX	0.1
UWTT2_IPMAX	0.15
UWTT3_IPMAX	0.9
UWTT4_IPMAX	0.925
UWTT5_IPMAX	1.075
UWTT6_IPMAX	1.1
IPMAX1	0
IPMAX2	1
IPMAX3	1
IPMAX4	1
IPMAX5	1.0001
IPMAX6	1.0001

Tab. 31: Values of WindLookupTableFunctionKind enum ipmax parameters for WTs type4.

enum iqmax	
UWTT1_IQMAX	0.1
UWTT2_IQMAX	0.15
UWTT3_IQMAX	0.9
UWTT4_IQMAX	0.925
UWTT5_IQMAX	1.075
UWTT6_IQMAX	1.1
IQMAX1	0
IQMAX2	1
IQMAX3	1
IQMAX4	0.33
IQMAX5	0.33
IQMAX6	1

Tab. 32: Values of WindLookupTableFunctionKind enum iqmax parameters for WTs type4.

QP and QU limitation control	
tpfiltql	0.01
tufiltql	0.01

Tab. 33: Values of QP and QU limitation control parameters.

enum qmaxp	
P1_QMAXP	0
P2_QMAXP	0.3
P3_QMAXP	1
QMAXP1	0
QMAXP2	0.33
QMAXP3	0.33

Tab. 34: Values of WindLookupTableFunctionKind enum qmaxp parameters.

enum qminp	
P1_QMINP	0
P2_QMINP	0.3
P3_QMINP	1
QMINP1	0
QMINP2	-0.33
QMINP3	-0.33

Tab. 35: Values of WindLookupTableFunctionKind enum qminp parameters.

enum qmaxu	
U1_QMAXU	0
U2_QMAXU	0.8
U3_QMAXU	0.9
QMAXU1	0
QMAXU2	0.33

QMAXU3	0.33
--------	------

Tab. 36: Values of WindLookupTableFunctionKind enum qmaxu parameters.

enum qminu	
U1_QMINU	0
U2_QMINU	0.8
U3_QMINU	0.9
QMINU1	0
QMINU2	-0.33
QMINU3	-0.33

Tab. 37: Values of WindLookupTableFunctionKind enum qminu parameters.

Control Q	
iqh1	1.05
iqmax	1.05
iqmin	-1.05
iqpost	0
kiq	0
kiu	0
kpq	1.1
kpu	2
kqv	2
rdroop	0
uref0	0
xdroop	0
uqdip	0.9
umin	0.9
udb1	1
udb2	2
umax	1.1
tqord	0
tpfiltq	0.01
tpost	0
tufiltq	0.01
windQcontrolModesType	1
windUVRTQcontrolModesType	0

Tab. 38: Values of Control Q parameters for WTs type 4.

A7. Parameters for WT type 4B

All the input parameters of Blocks/Functionalities used for WT Type 4B are equal than previous ones of WT Type 4A (paragraph A6). The difference between WTs type 4A and 4B is about the following input block parameters (Tab. 39 and Tab. 40):

P control type 4B	
dpmax4b	1
tpaereo	0.5
tpordp4b	0.01
tufiltp4b	0.01

Tab. 39: Values of P control type 4B parameters.

Mechanical Two mass	
cdrt	0.8
hgen	0.7275
hwtr	4.225
kdr	140

Tab. 40: Values of Mechanical (Two mass) parameters for WT type 4B.

List of Figures

FIG. 1: MAIN ELECTRICAL AND MECHANICAL COMPONENTS OF TYPE 1 WTS [1].	3
FIG. 2: SYSTEM DESCRIPTION WT1A	3
FIG. 3: SOME RESULTS BY WT1A SIMULATION	4
FIG. 4: SYSTEM DESCRIPTION WT1B	4
FIG. 5: SOME RESULTS BY WT1B SIMULATION	4
FIG. 6: MODULAR STRUCTURE FOR THE TYPE 1A WT MODEL [1].	5
FIG. 7: MODULAR STRUCTURE FOR THE TYPE 1B WT MODEL [1].	5
FIG. 8: MAIN ELECTRICAL AND MECHANICAL COMPONENTS OF TYPE 2 WTS [1].	6
FIG. 9: SYSTEM DESCRIPTION TYPE 2 WT	6
FIG. 10: SOME RESULTS BY WT2 SIMULATION.	6
FIG. 11: MODULAR STRUCTURE FOR THE TYPE 2 WT MODEL [1].	7
FIG. 12: MAIN ELECTRICAL AND MECHANICAL COMPONENTS OF TYPE 3 WTS [1].	8
FIG. 13: SYSTEM DESCRIPTION TYPE 3A WT.	8
FIG. 14: SYSTEM DESCRIPTION TYPE 31A WT.	8
FIG. 15: SOME RESULTS BY WT3A SIMULATION.	9
FIG. 16: SYSTEM DESCRIPTION TYPE 3B WT.	9
FIG. 17: SOME RESULTS BY WT3B SIMULATION.	9
FIG. 18: MODULAR STRUCTURE FOR THE TYPE 3 WT MODEL [1].	10
FIG. 19: MODULAR STRUCTURE FOR THE TYPE 3 WT CONTROL MODEL [1].	11
FIG. 20: MAIN ELECTRICAL AND MECHANICAL COMPONENTS OF TYPE 4 WTS [1].	11
FIG. 21: SYSTEM DESCRIPTION TYPE 4A WT.	12
FIG. 22: SYSTEM DESCRIPTION TYPE 41A WT.	12
FIG. 23: SOME RESULTS BY WT4A SIMULATION.	13
FIG. 24: SYSTEM DESCRIPTION TYPE 4B WT.	13
FIG. 25: SOME RESULTS BY WT4B SIMULATION.	14
FIG. 26: MODULAR STRUCTURE FOR THE TYPE 4A WT MODEL [1].	14
FIG. 27: MODULAR STRUCTURE FOR THE TYPE 4A CONTROL MODEL [1].	15
FIG. 28: MODULAR STRUCTURE FOR THE TYPE 4B WT MODEL [1].	15
FIG. 29: MODULAR STRUCTURE FOR THE TYPE 4B CONTROL MODEL [1].	16

List of Tables

TAB. 1: CGMES BLOCKS/FUNCTIONALITIES OVERVIEW	2
TAB. 2: VALUES OF MECHANICAL (TWO MASS) PARAMETERS FOR WT TYPE 1.	18
TAB.3: VALUES OF PITCH CONTROL POWER MODEL PARAMETERS.	18
TAB. 4: VALUES OF WINDLOOKUPTABLEFUNCTIONKIND ENUM TDUWT PARAMETERS FOR WT TYPE 1B.	18
TAB. 5: VALUES OF MECHANICAL (TWO MASS) PARAMETERS FOR WT TYPE 2.	19
TAB. 6: VALUES OF PITCH CONTROL POWER MODEL PARAMETERS.	19
TAB. 7: VALUES OF WINDLOOKUPTABLEFUNCTIONKIND ENUM TDUWT PARAMETERS FOR WT TYPE 2.	19
TAB. 8: VALUES OF ROTOR RESISTANCE CONTROL PARAMETERS.	19
TAB. 9: VALUES OF WINDLOOKUPTABLEFUNCTIONKIND ENUM PRR PARAMETERS.	20
TAB. 10: VALUES OF WINDTURBINETYPE3 PARAMETERS FOR TYPE 3A.	20
TAB. 11: VALUES OF GENERATOR SYSTEM TYPE 3A PARAMETERS.	20
TAB. 12: VALUES OF AERODYNAMIC ONE-DIMENSIONAL PARAMETERS.	20
TAB. 13: VALUES OF AERODYNAMIC TWO-DIMENSIONAL PARAMETERS.	20
TAB. 14: VALUES OF WINDLOOKUPTABLEFUNCTIONKIND ENUM OMEGAP PARAMETERS.	21
TAB. 15: VALUES OF CONTROL P TYPE 3 PARAMETERS.	21
TAB. 16: VALUES OF CONSTANT Q LIMITATION PARAMETERS FOR WT TYPE 3.	22
TAB. 17: VALUES OF REFERENCE FRAME ROTATION MODEL PARAMETERS FOR WT TYPE 3..	22
TAB. 18: VALUES OF CONTROL Q PARAMETERS FOR WTS TYPE 3.	22
TAB. 19: VALUES OF PITCH ANGLE CONTROL PARAMETERS.	23
TAB. 20: VALUES OF MECHANICAL (TWO MASS) PARAMETERS FOR WTS TYPE 3.	23
TAB. 21: VALUES OF CURRENT LIMITATION CONTROL PARAMETERS FOR WTS TYPE 3.	23
TAB. 22: VALUES OF WINDLOOKUPTABLEFUNCTIONKIND ENUM IPMAX PARAMETERS FOR WTS TYPE3.	23
TAB. 23: VALUES OF WINDLOOKUPTABLEFUNCTIONKIND ENUM IQMAX PARAMETERS FOR WTS TYPE3.	24
TAB. 24: VALUES OF WINDTURBINETYPE3 PARAMETERS FOR TYPE 3B.	24
TAB. 25: VALUES OF GENERATOR SYSTEM TYPE 3B PARAMETERS.	24
TAB. 26: VALUES OF GENERATOR SYSTEM TYPE 4IEC PARAMETERS.	24
TAB. 27: VALUES OF P CONTROL TYPE 4A PARAMETERS	25
TAB. 28: VALUES OF CONSTANT Q LIMITATION PARAMETERS FOR WT TYPE 4.	25
TAB. 29: VALUES OF REFERENCE FRAME ROTATION MODEL PARAMETERS FOR WT TYPE 4.	25
TAB. 30: VALUES OF CURRENT LIMITATION CONTROL PARAMETERS FOR WT TYPE 4.	25
TAB. 31: VALUES OF WINDLOOKUPTABLEFUNCTIONKIND ENUM IPMAX PARAMETERS FOR WTS TYPE4.	25
TAB. 32: VALUES OF WINDLOOKUPTABLEFUNCTIONKIND ENUM IQMAX PARAMETERS FOR WTS TYPE4.	26
TAB. 33: VALUES OF QP AND QU LIMITATION CONTROL PARAMETERS.	26

TAB. 34: VALUES OF WINDLOOKUPTABLEFUNCTIONKIND ENUM QMAXP PARAMETERS.	26
TAB. 35: VALUES OF WINDLOOKUPTABLEFUNCTIONKIND ENUM QMINP PARAMETERS.	26
TAB. 36: VALUES OF WINDLOOKUPTABLEFUNCTIONKIND ENUM QMAXU PARAMETERS.	27
TAB. 37: VALUES OF WINDLOOKUPTABLEFUNCTIONKIND ENUM QMINU PARAMETERS.	27
TAB. 38: VALUES OF CONTROL Q PARAMETERS FOR WTS TYPE 4.	27
TAB. 39: VALUES OF P CONTROL TYPE 4B PARAMETERS.	28
TAB. 40: VALUES OF MECHANICAL (TWO MASS) PARAMETERS FOR WT TYPE 4B.	28