

## Features

- Calculation of max. MW transfer between regions
- ETSO methodology (load flow based, MW generation shift)
- Large flexibility in limit handling (individual activation of limits)
- Consideration of user-defined contingency scenarios
- Consideration of TRM (Transmission Reliability Margin)

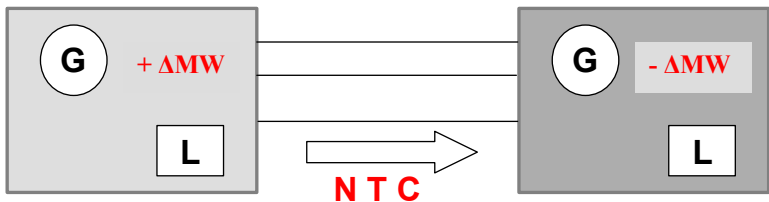
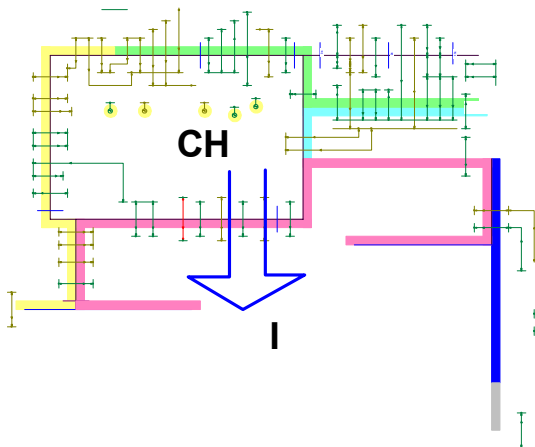

Generation shift from source to sink

## Results

Report for every step of MW transfer on:

- Limit violations for base case
- Limit violations for each contingency case
- Calculation of TTC (Total transfer capacity) and NTC (Net transfer capacity)

