

Dynamic Wind Power Plant Simulation with NEPLAN

A short overview how to model wind turbines and wind power plants in NEPLAN

In this brochure it is shown how simple it is to model and simulate wind power plants with the power system analysis tool NEPLAN. We will explain the different modeling approaches in the NEPLAN simulator on a typical example: a DFIG (Double-Fed Induction Generator) connected to an external grid.

Once you have modeled the power system network in NEPLAN, then the dynamic simulator allows you to analyze the system either in the **DQ (for balanced systems)** or in **ABC (for unbalance 3-phase system) mode**. In symmetrical network condition the DQ simulation is much faster than the ABC simulation. However, if you need to model any type of unsymmetrical condition the ABC simulation is the first choice.

Any dynamic model (e.g. wind turbine) in NEPLAN may be entered and defined in different ways, each of them have advantages and disadvantages:

- Entering a NEPLAN predefined standard dynamic model (e.g. wind turbine)
- Entering a user defined dynamic model (e.g. wind turbine) with function blocks
- Entering a user defined dynamic model as DLL file, written with equations and modeled with Matlab.

Basically NEPLAN offers two possibilities to connect a DFIG, the turbines and the controllers to the power system network:

- 1) A very simple approach allows connecting a standard DFIG with turbine and controllers directly to the AC network. This allows very effectively studying the overall influence of the wind farm to the utility's network.
- 2) The more detailed model in NEPLAN uses a DFIG model, which allows graphically connecting external elements like a PWM to the rotor and the grid to the stator side of the DFIG. This allows studying all dynamic effects in detail. Turbine manufactures and researchers may build up their own turbine and controllers either with the NEPLAN function block editor or via a dynamic link library (a binary DLL file). The equations for the model may be entered in Matlab. The DLL file will then be automatically generated with our NEPLAN Matlab tools.

Entering a simplified wind turbine model for network studies

Utilities may study many influences of a wind power plant to their power system network with the NEPLAN simplified wind turbine model. Data entering is very simple. You connect the machine to the busbar and add a wind turbine symbol to the single line diagram. The wind turbine dialog includes all parameters for wind speed, turbine and controllers. This is the easiest way to enter a wind turbine model and its controllers.

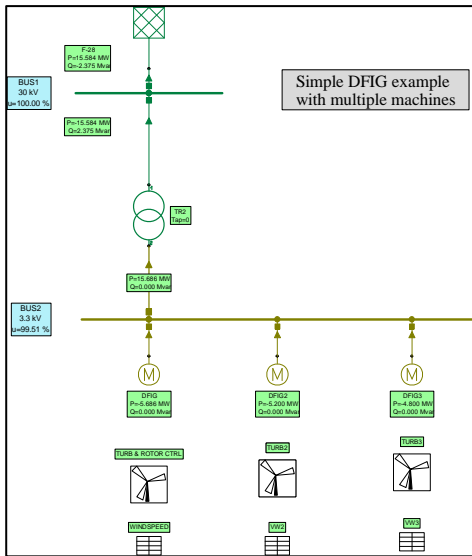
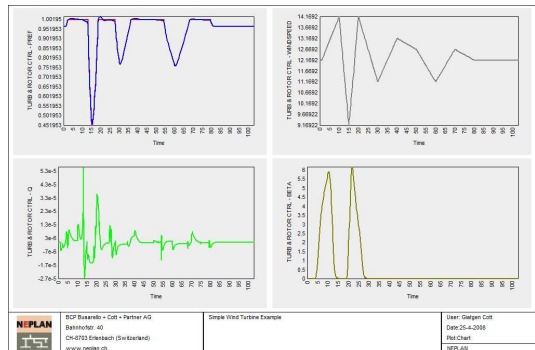

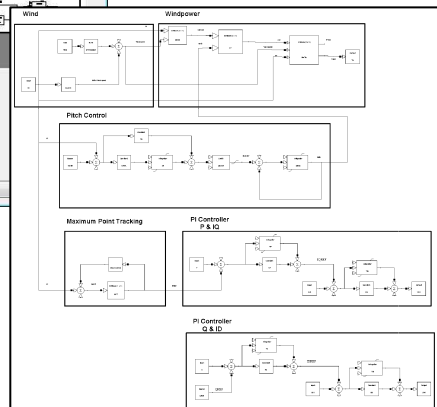

Name	Value
1 KP	1.0
2 TP	0.1
3 KQ	1.0
4 TQ	0.1
5 KID	0.2
6 TIQ	0.01
7 KID	0.2
8 TID	0.01
9 IROTMAX	2
10 RC	0.1
11 KC	0.1
12 WREF	1.2
13 KA	100
14 TA	5
15 TR	1
16 T	0.5
17 VRMIN	0

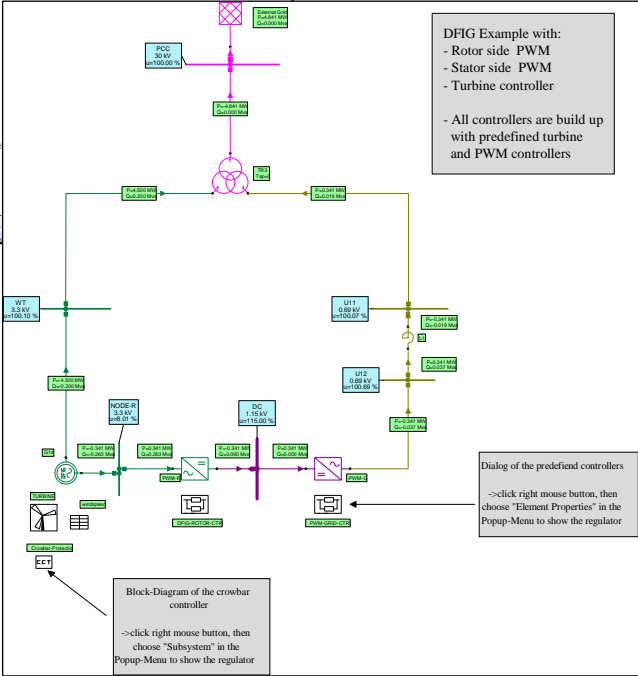
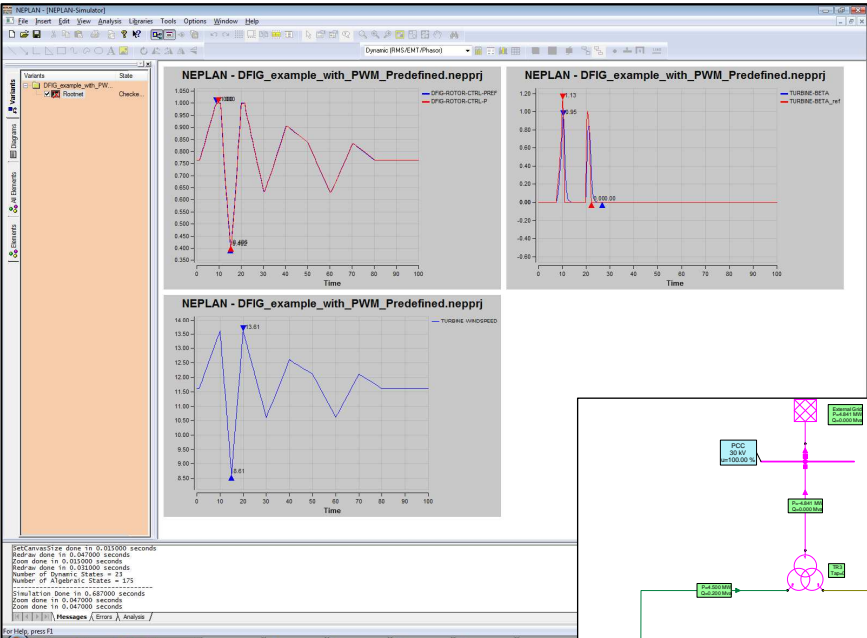

Entering a predefined wind turbine model with PWM and their predefined controllers

The DFIG, the turbine and the rotor and the grid side PWM have to be inserted first. Then with just a mouse click the predefined PWM controllers may be assigned. That is all. Now the dynamic simulation may be started either in DQ (for balanced systems) or ABC (for unsymmetrical 3-phase system) mode.



**Wind power example with DFIG, Turbine and PWM
Output curves: blade angle and power**

DFIG - Double-Fed Induction Generator Input Data

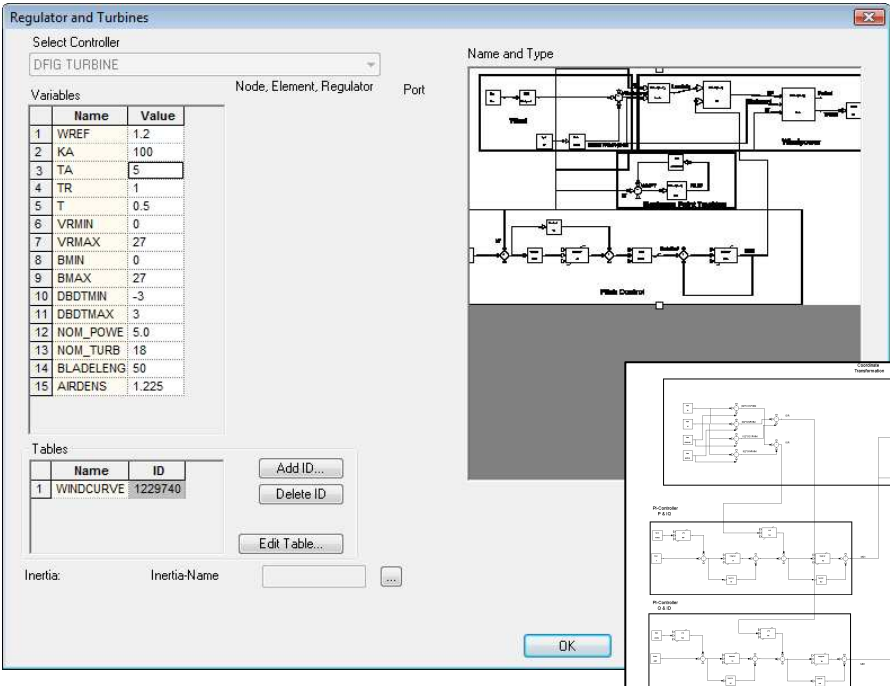
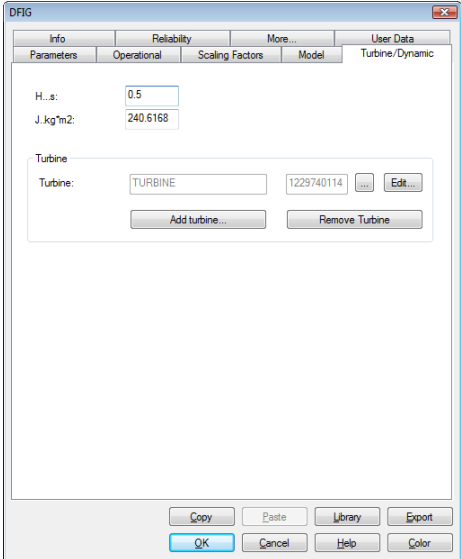
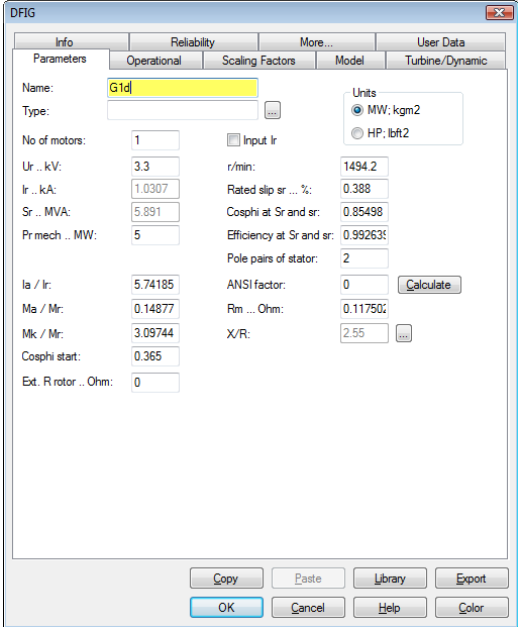

Inserting the predefined turbine and adding the wind curve

Defining wind turbine models and PWM controllers using the NEPLAN function block diagram editor.

NEPLAN provides all the functionalities to build up the turbine and the PWM controllers through user defined block diagrams. The block diagram may be build up very easily with the graphical function block editor. NEPLAN has many predefined function blocks available. In case a needed function block should not be available in NEPLAN, then the user may define its own function block (e.g. FFT, special mathematical functions, etc.).

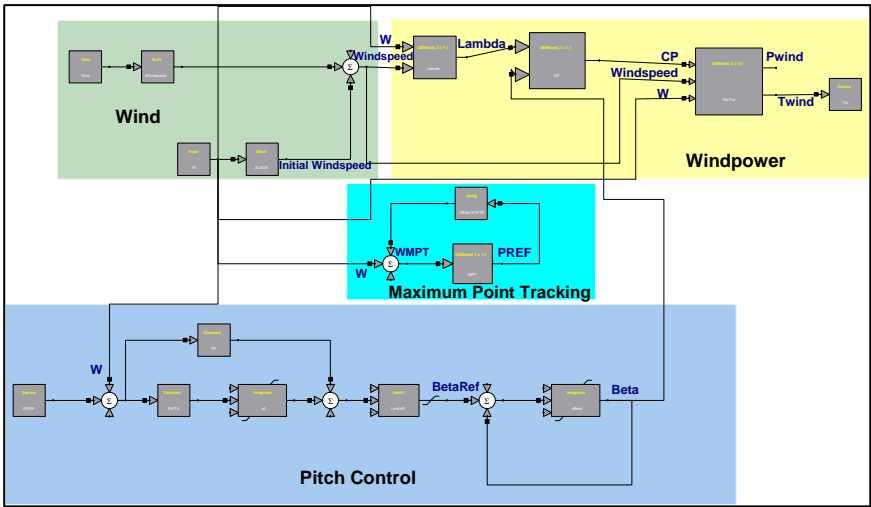

Wind Turbine controllers build up with the NEPLAN function block editor

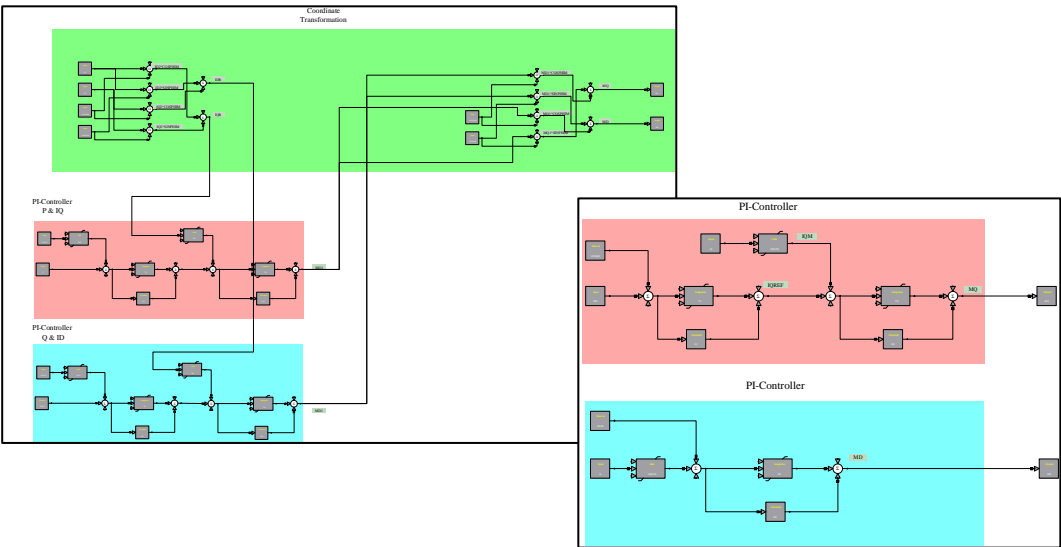

Rotor and grid side PWM controllers

Defining wind turbine models and PWM controllers using the NEPLAN Matlab functionalities

NEPLAN provides the possibility to build up a wind turbine model with a dynamic link library (DLL file). That allows a manufacturer to hide its turbine and controller know-how into a binary format. The development of such a controller may be done with equations within Matlab. NEPLAN provides functionalities within Matlab to create automatically the binary DLL file which will then be used for the NEPLAN dynamic simulator. The parameters of the controllers may be changed in a dialog NEPLAN. All input/output signals or variables of the controllers are available for external use. That allows for example to connect any signal/variable of the user defined model to any variable of the system.

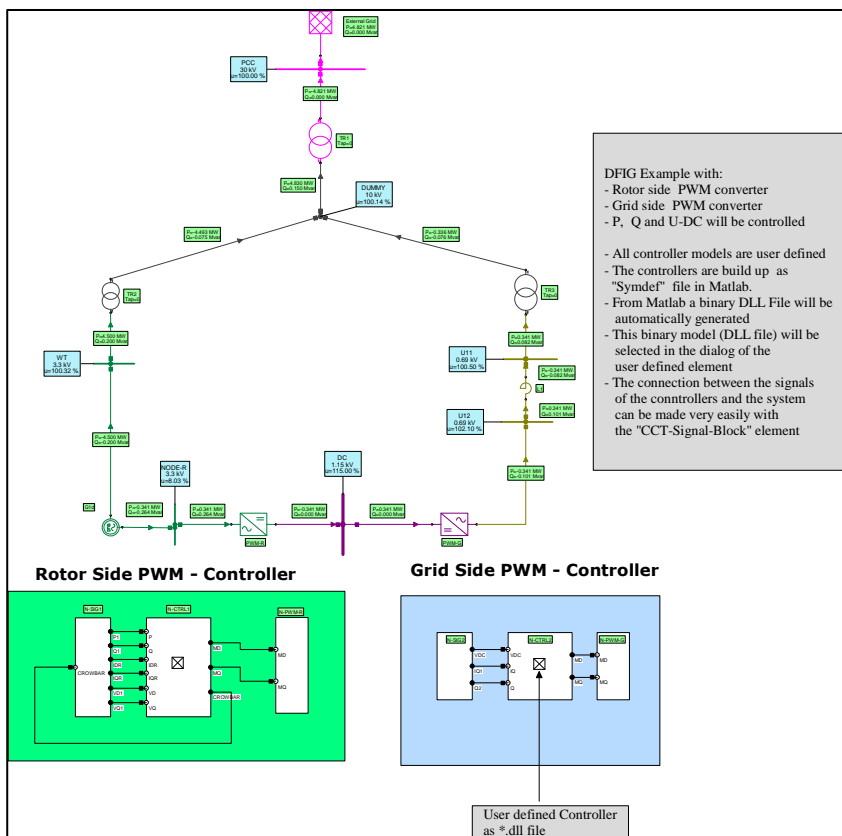

PWM controllers defined as binary DLL file. The input/output signals may be connected to other variables in the system (e.g. P, Q of the rotor of the DFIG model)

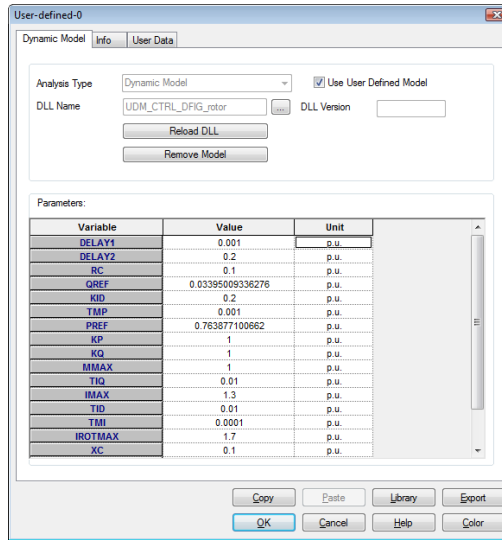

Parameter list of the PWM controller which is defined in the user defined binary dll file “UDM_CTRL_DFIG-rotor”

```

%-----
definitions:
%-----
dynamic_states x1 x2 x3 x4 IDM=0.001 IQM PM=0.001 QM
external_states MD=0.001 MQ P Q
external_states IDR=0.001 IQR VD=1 VQ CROWBAR
internal_states IDREF IQREF
parameters KP TP KQ TQ
parameters KIQ TIQ KID TID
parameters PREF QREF RC XC MMAX IMAX TMI TMP IROTMAX DELAY1 DELAY2
%-----
initializations:
%-----

%-----
f_equations:
%-----

%-----
% Vqr - control
%-----
dt(x1) = (PREF-PM)/TP
dt(x2) = (QREF-QM)/TQ
dt(x3) = (IQREF-IQM)/TIQ
dt(x4) = (IDREF-IDM)/TID
dt(IDM) = 1/TMI*(IDR - IDM)
dt(IQM) = 1/TMI*(IQR - IQM)
dt(PM) = 1/TMP*(P - PM)
dt(QM) = 1/TMP*(Q - QM)
%-----
% Vdr - control
%-----

%-----
g_equations:
%-----

%-----
% PQ - control
%-----
g3 = (MD*VD+MQ*VQ) - (KIQ*(IQREF-IQM) + x3)*sqrt(VD*VD+VQ*VQ)
g4 = (MD*VQ-MQ*VD) - (KID*(IDREF-IDM) + x4)*sqrt(VD*VD+VQ*VQ)
g7 = IQREF - (KP*(PREF-PM) + x1)
g8 = IDREF - (KQ*(QREF-QM) + x2)
g15 = CROWBAR - 0

%-----
h_equations:
%-----

```

Definition of the controller equations in Matlab

The binary DLL file will be automatically generated with the NEPLAN Matlab functionalities